



**User Manual**  
***MODEL 465L + O<sub>2</sub>***  
***Industrial Ozone Analyzer***  
***with Oxygen Sensor***

Teledyne API (TAPI)  
9970 Carroll Canyon Road  
San Diego, CA 92131-1106

Phone: 800-324-5190 (toll free)  
+1 858-657-9800  
FAX: +1 858-657-9816  
Email: [api-sales@teledyne.com](mailto:api-sales@teledyne.com)  
Website: <http://www.teledyne-api.com/>



# WARRANTY

---

## WARRANTY POLICY (02024J)

Teledyne API (TAPI), a business unit of Teledyne Instruments, Inc., provides that:

Prior to shipment, TAPI equipment is thoroughly inspected and tested. Should equipment failure occur, TAPI assures its customers that prompt service and support will be available. (For the instrument-specific warranty period, please refer to the “Limited Warranty” section in the Terms and Conditions of Sale on our website at the following link: [http://www.teledyne-api.com/terms\\_and\\_conditions.asp](http://www.teledyne-api.com/terms_and_conditions.asp)).

## COVERAGE

After the warranty period and throughout the equipment lifetime, TAPI stands ready to provide on-site or in-plant service at reasonable rates similar to those of other manufacturers in the industry. All maintenance and the first level of field troubleshooting are to be performed by the customer.

## NON-TAPI MANUFACTURED EQUIPMENT

Equipment provided but not manufactured by TAPI is warranted and will be repaired to the extent and according to the current terms and conditions of the respective equipment manufacturer’s warranty.

## PRODUCT RETURN

All units or components returned to Teledyne API should be properly packed for handling and returned freight prepaid to the nearest designated Service Center. After the repair, the equipment will be returned, freight prepaid.

The complete Terms and Conditions of Sale can be reviewed at [http://www.teledyne-api.com/terms\\_and\\_conditions.asp](http://www.teledyne-api.com/terms_and_conditions.asp)

### CAUTION – Avoid Warranty Invalidation



Failure to comply with proper anti-Electro-Static Discharge (ESD) handling and packing instructions and Return Merchandise Authorization (RMA) procedures when returning parts for repair or calibration may void your warranty. For anti-ESD handling and packing instructions please refer to the manual, Fundamentals of ESD, PN 04786, in its “Packing Components for Return to Teledyne API’s Customer Service” section. The manual can be downloaded from our website at <http://www.teledyne-api.com>. RMA procedures can also be found on our website.

## **NOTICE OF COPYRIGHT**

© 2013-2018 TAPI.

## **Trademarks**

All trademarks, registered trademarks, brand names or product names appearing in this document are the property of their respective owners and are used herein for identification purposes only.

## IMPORTANT SAFETY INFORMATION

---

Important safety messages are provided throughout this manual for the purpose of avoiding personal injury or instrument damage. Please read these messages carefully. Each safety message is associated with a safety alert symbol and placed throughout this manual and inside the instrument. The symbols with messages are defined as follows:



**WARNING:** Electrical Shock Hazard



**HAZARD:** Strong oxidizer



**GENERAL WARNING/CAUTION:** Read the accompanying message for specific information.



**CAUTION:** Hot Surface Warning



**Do Not Touch:** Touching some parts of the instrument without protection or proper tools could result in damage to the part(s) and/or the instrument.



**Technician Symbol:** All operations marked with this symbol are to be performed by qualified maintenance personnel only.



**Electrical Ground:** This symbol inside the instrument marks the central safety grounding point for the instrument.

### CAUTION GENERAL SAFETY HAZARD



**This instrument should only be used for the purpose and in the manner described in this manual. If you use it in a manner other than that for which it was intended, unpredictable behavior could ensue with possible hazardous consequences.**

**NEVER use any gas analyzer to sample combustible gas(es).**

## CONSIGNES DE SÉCURITÉ

Des consignes de sécurité importantes sont fournies tout au long du présent manuel dans le but d'éviter des blessures corporelles ou d'endommager les instruments. Veuillez lire attentivement ces consignes. Chaque consigne de sécurité est représentée par un pictogramme d'alerte de sécurité; ces pictogrammes se retrouvent dans ce manuel et à l'intérieur des instruments. Les symboles correspondent aux consignes suivantes :



**AVERTISSEMENT** : Risque de choc électrique



**DANGER** : Oxydant puissant



**AVERTISSEMENT GÉNÉRAL / MISE EN GARDE** : Lire la consigne complémentaire pour des renseignements spécifiques



**MISE EN GARDE** : Surface chaude



**Ne pas toucher** : Toucher à certaines parties de l'instrument sans protection ou sans les outils appropriés pourrait entraîner des dommages aux pièces ou à l'instrument.



**Pictogramme « technicien »** : Toutes les opérations portant ce symbole doivent être effectuées uniquement par du personnel de maintenance qualifié.



**Mise à la terre** : Ce symbole à l'intérieur de l'instrument détermine le point central de la mise à la terre sécuritaire de l'instrument.

### MISE EN GARDE



**Cet instrument doit être utilisé aux fins décrites et de la manière décrite dans ce manuel. Si vous utilisez cet instrument d'une autre manière que celle pour laquelle il a été prévu, l'instrument pourrait se comporter de façon imprévisible et entraîner des conséquences dangereuses.**

**NE JAMAIS utiliser un analyseur de gaz pour échantillonner des gaz combustibles!**

## ABOUT THIS MANUAL

This manual is comprised of the following documents:

<b>Part Number</b>	<b>Name/Description</b>
07795	465L +O <sub>2</sub> User Manual (this manual)
059100100	Spare Parts List (integrated into this manual as Section 11.1)

### NOTE

We recommend that this manual be read in its entirety before making any attempt to operate the instrument.

This page intentionally left blank.



# TABLE OF CONTENTS

---

<b>SAFETY MESSAGES</b> .....	<b>iii</b>
<b>ABOUT THIS MANUAL</b> .....	<b>v</b>
<b>1. INTRODUCTION</b> .....	<b>11</b>
1.1. PREFACE .....	11
<b>2. SPECIFICATIONS AND AGENCY APPROVALS</b> .....	<b>13</b>
2.1. SPECIFICATIONS .....	13
2.2. APPROVALS .....	14
2.2.1. Safety .....	14
2.2.2. EMC .....	14
2.2.3. Other Type Certifications .....	14
<b>3. PRINCIPLES OF OPERATION</b> .....	<b>15</b>
3.1. OZONE MONITOR .....	15
3.2. OXYGEN SENSOR .....	16
3.2.1. Construction .....	17
3.2.2. Oxygen Measurements .....	17
<b>4. GETTING STARTED</b> .....	<b>19</b>
4.1. WIRING REQUIREMENTS FOR NEMA ENCLOSURES .....	20
4.2. WIRING INSTRUCTIONS .....	21
4.3. PNEUMATIC CONNECTIONS .....	23
4.3.1. Sample Gas Connection .....	23
4.3.2. Exhaust Connection .....	27
4.3.3. Electrical Connections .....	27
4.3.4. Location of I/O Connectors .....	28
4.3.5. Analog Output .....	28
4.3.6. Status Outputs .....	28
4.3.7. Hi-Current Relay Outputs .....	29
4.3.8. Digital Serial Interfaces .....	30
<b>5. OPTIONS</b> .....	<b>31</b>
5.1. DISPOSABLE SAMPLE INLET FILTERS .....	31
5.2. ELECTRONIC FLOWMETER .....	31
5.3. SAMPLE CONDITIONER .....	31
5.4. PERMEATION GAS DRYER .....	31
<b>6. OPERATION</b> .....	<b>33</b>
6.1. FRONT PANEL OVERVIEW .....	33
6.1.1. Gas Concentration Display .....	33
6.1.2. Menu Navigation Keypad .....	34
6.1.3. Concentration Alarm Status/Reset .....	34
6.1.4. Status LEDs .....	34

6.2.	FRONT PANEL MENUS .....	35
6.2.1.	Menu Navigation Basics .....	35
6.2.2.	Editing Numeric Values .....	35
6.2.3.	SETUP Menu .....	38
6.2.4.	DIAG Menu.....	41
6.2.5.	VIEW Menu .....	46
6.2.6.	CONFIG Menu .....	46
<b>7.</b>	<b>DIGITAL COMMUNICATIONS .....</b>	<b>47</b>
7.1.	DIGITAL COMMUNICATIONS OVERVIEW .....	47
7.2.	CHANGING COM PORT HARDWARE CONFIGURATION .....	47
7.3.	RS-232 CONFIGURATION.....	49
7.4.	RS-485 CONFIGURATION.....	50
7.5.	ETHERNET CONFIGURATION .....	51
7.5.1.	Hardware Setup for Configuring the Ethernet Module .....	51
7.5.2.	Verifying Network Hardware Connection .....	51
7.5.3.	Determining a Dynamically Assigned IP Address (DHCP Mode) .....	52
7.5.4.	Manually Assigning a Static IP Address.....	52
7.6.	MODBUS REGISTER MAPS .....	53
7.6.1.	MODBUS Commands Supported .....	53
7.6.2.	Notes on MODBUS registers .....	53
7.6.3.	Real-Time Concentration and Status Registers (Read Only).....	54
7.6.4.	Instrument Setup and Configuration Registers (Read / Write).....	55
<b>8.</b>	<b>MAINTENANCE AND ADJUSTMENTS .....</b>	<b>57</b>
8.1.	MAINTENANCE SCHEDULE .....	57
8.2.	INSTRUMENT LAYOUT.....	58
8.3.	REPLACING THE INTERNAL PARTICULATE FILTER.....	59
8.4.	UV LAMP ADJUSTMENT.....	59
8.5.	UV LAMP REPLACEMENT .....	60
8.6.	SAMPLE PUMP REPLACEMENT .....	61
8.7.	O <sub>3</sub> SENSOR VALVE REPLACEMENT.....	62
8.8.	O <sub>2</sub> SENSOR REPLACEMENT .....	63
8.9.	WATER DROP-OUT FILTER (OPTION) MAINTENANCE .....	63
8.10.	CONFIGURING THE ANALOG OUTPUT .....	64
8.11.	CLEANING EXTERIOR SURFACES OF THE M465L .....	65
8.12.	BOOT LOADER OPERATION .....	65
8.12.1.	Boot Loader – Hardware Setup .....	65
8.12.2.	Boot Loader – Software Setup .....	65
<b>9.</b>	<b>TROUBLESHOOTING .....</b>	<b>69</b>
9.1.	REFERENCE DRAWINGS .....	69
9.1.1.	Interconnect Diagram .....	69
9.2.	TROUBLESHOOTING BY FRONT PANEL STATUS LED'S/STATUS OUTPUTS.....	70
9.2.1.	Sensor OK.....	72
9.2.2.	Invalid Reading.....	72
9.2.3.	Check Lamp .....	72
9.2.4.	Pneumatic Error .....	72

9.3. TECHNICAL SUPPORT .....73

**10. CALIBRATION .....75**

10.1. FACTORY CALIBRATION .....75

10.2. ZERO CALIBRATION.....75

**11. SPARE PARTS .....77**

11.1. M465L + O<sub>2</sub> SPARE PARTS LIST.....77

**FIGURES**

Figure 3-1. Fuel Cell Transducer.....17

Figure 4-1: Mounting Hole Locations and Dimensions.....20

Figure 4-2: AC Power Connection to Monitor.....21

Figure 4-3: Pneumatic Connections .....23

Figure 4-4: Pneumatic Diagram with Sample Conditioner and Permeation Gas Dryer  
Options.....25

Figure 4-5: Electrical I/O Connections.....27

Figure 4-6: Status Output Schematic .....28

Figure 6-1: Front Panel Display.....33

Figure 6-2: Front Panel Menu Diagram.....36

Figure 6-3: Front Panel Menu Diagram, VARS Menu Details .....37

Figure 6-4: Front Panel Menu Diagram, O<sub>2</sub> Menu Details.....37

Figure 6-5: Span Cal Menu .....44

Figure 6-6: Flow Cal Menu .....45

Figure 7-1: DIP Switch Location (SW3) .....48

Figure 7-2: Com Configuration Jumper Settings (SW2).....48

Figure 8-1: Instrument Layout.....58

Figure 8-2: O<sub>3</sub> Sensor Detail .....62

Figure 8-3: Mainboard – Analog Output Configuration.....64

Figure 9-1: Interconnect Diagram.....70

**TABLES**

Table 2-1: Model 465L+O <sub>2</sub> Specifications .....	13
Table 4-1: Status Output Definitions .....	29
Table 4-2: Relay Functions .....	29
Table 6-1: Status LED's .....	34
Table 6-2: STREAM Parameters .....	38
Table 6-3: VARS List.....	39
Table 6-4. O <sub>2</sub> Parameters .....	40
Table 6-5: Analog Step Test Values .....	41
Table 6-6: Signal I/O List.....	42
Table 6-7: VIEW Menu Parameters .....	46
Table 6-8: CONFIG Menu Parameters.....	46
Table 7-1: RS-232 Connector Details .....	49
Table 7-2: RS-232 Port Setup.....	49
Table 7-3: RS-485 Connector Details .....	50
Table 7-4: RS-485 Port Setup.....	50
Table 7-5: Ethernet LED Definitions.....	51
Table 7-6: Supported MODBUS Commands .....	53
Table 8-1: Maintenance Schedule .....	57
Table 8-2: Required Software .....	65
Table 9-1: Status LED/Output Definitions .....	71

# 1. INTRODUCTION

---

## 1.1. Preface

The Teledyne API Model 465L +O<sub>2</sub> (typically referred to as M456L herein) is a UV photometric ozone monitor designed and manufactured for industrial hygiene ozone analysis with the added capability of O<sub>2</sub> sensing. It is a very stable analyzer, ideal for critical low-level PPM safety and process applications. The M465L is designed to be highly reliable and simple to operate with easy setup and user-friendly menu driven software that can also be set and monitored remotely.

As the M465L was designed for stability, reliability and simplicity, it includes built-in tests and diagnostics to facilitate maximum uptime. In addition to our warranty, Teledyne API is pleased to provide you with any support required so that you may utilize our equipment to the fullest extent. Our full time Technical Support department is available to answer your questions.

This page intentionally left blank.

## 2. SPECIFICATIONS AND AGENCY APPROVALS

### 2.1. Specifications

**Table 2-1: Model 465L+O<sub>2</sub> Specifications**

PARAMETER	DESCRIPTION	
	O <sub>3</sub>	O <sub>2</sub>
Ranges	User selectable to any full scale range from: 1 PPM to 500 PPM or 1000 PPB to 10,000 PPB Low conc scrubber configuration: 0 to 20 PPM High conc scrubber configuration: >20 PPM	User selectable to any full scale range from 0.1% to 100%
Measurement Units	PPM, PPB	% by volume
Zero Noise	< .0015 PPM (rms)	0.001%
Span Noise	< .5% of reading (rms) (above 0.1 PPM)	0.05%
Lower Detectable Limit	< .003 PPM (rms)	0.01% by volume
Accuracy	+/- 1% of full scale range	+/- 1% of full scale range at constant temperature and pressure
Global Alarm Relays	SPDT (Form C) Dry Contact, 250 VAC, 5A (x2, HI and HI-HI)	SPDT (Form C) Dry Contact, 250 VAC, 5A (x2, HI/LO and HI-HI)
Pressure	N/A	+/- 0.1% of the reading itself to 4500 ft (12.5 psi)
Response Time (95%)	<30 sec (<60 sec with the Sample Conditioner option)	
Sample Flow Rate	0.8 L/min	
Temperature Range	5-45° C	
Humidity Range	10-90% RH, Non-Condensing	
Dimensions (H x W x D)	16.85" x 15.60 (±0.25)" x 6.65" (428mm x 396 (±6.35)mm x 169mm) with NEMA 4X enclosure, typical product envelope	
Weight	15.2 lb. (6.91 kg)	
Power	100-240 V~, 47-63 Hz, 74 W	

PARAMETER	DESCRIPTION
Environmental Conditions	Installation Category (Overvoltage Category) II Pollution Degree 2 For Indoor Use Only Maximum Operating Altitude 2000 meters
Analog Outputs, Voltage Mode	0 - 5V
Isolated Analog Outputs, 4-20mA Mode	Maximum voltage between outputs and ground 60V peak
System OK Status Relay	SPDT (Form C) Dry Contact, 250 VAC, 5A
Instrument Status Outputs	6 - SPST Dry Contact, 50VDC, 250mA Resistive Load

## 2.2. Approvals

This section presents Safety and Electromagnetic Compatibility (EMC) compliance approvals for the Model 465L monitor.

### 2.2.1. Safety

IEC 61010-1:2001, Safety requirements for electrical equipment for measurement, control, and laboratory use.

CE: 2006/95/EC, Low-Voltage Directive

### 2.2.2. EMC

EN 61326-1 (IEC 61326-1), Class A Emissions/Industrial Immunity

EN 55011 (CISPR 11), Group 1, Class A Emissions

FCC 47 CFR Part 15B, Class A Emissions

CE: 2004/108/EC, Electromagnetic Compatibility Directive

### 2.2.3. Other Type Certifications

For additional certifications, please contact Technical Support:

**Toll-free:** 800-324-5190

**Phone:** 858-657-9800

**Fax:** 858-657-9816

**Email:** [api-techsupport@teledyne.com](mailto:api-techsupport@teledyne.com)



## 3. PRINCIPLES OF OPERATION

---

This section presents the principles of operation for the Ozone sensor and for the Oxygen sensor.

### 3.1. Ozone Monitor

The detection of ozone molecules is based on absorption of 254 nm UV light due to an internal electronic resonance of the O<sub>3</sub> molecule. The Model 465L uses a mercury lamp constructed so that a majority of the light emitted is at the 254nm wavelength. Light from the lamp shines down a hollow quartz tube that is alternately filled with sample gas, then filled with gas scrubbed to remove ozone. The ratio of the intensity of light passing through the scrubbed gas to that of the sample forms a ratio  $I/I_0$ . This ratio forms the basis for the calculation of the ozone concentration.

The Beer-Lambert equation, shown below, calculates the concentration of ozone from the ratio of light intensities.

$$C_{O_3} = -\frac{10^9}{\alpha \times \ell} \times \frac{T}{273^\circ\text{K}} \times \frac{29.92\text{inHg}}{P} \times \ln \frac{I}{I_0}$$

**Equation 3-1. Ozone Concentration Calculation**

Where:

I = Intensity of light passed through the sample

I<sub>0</sub> = Intensity of light through sample free of ozone

α = absorption coefficient

ℓ = path length

C<sub>O<sub>3</sub></sub> = concentration of ozone in ppb

T = sample temperature in degrees Kelvin

P = pressure in inches of mercury

As can be seen the concentration of ozone depends on more than the intensity ratio. Temperature and pressure influence the density of the sample. The density changes the number of ozone molecules in the absorption tube which impacts the amount of light removed from the light beam. These effects are addressed by directly measuring temperature and pressure and including their actual values in the calculation. The absorption coefficient is a number that reflects the inherent ability of ozone to absorb 254 nm light. Most current measurements place this value at

308 cm<sup>-1</sup> atm<sup>-1</sup> at STP. The value of this number reflects the fact that ozone is a very efficient absorber of UV radiation which is why stratospheric ozone protects the life forms lower in the atmosphere from the harmful effects from solar UV radiation. Lastly, the absorption path length determines how many molecules are present in the column of gas in the absorption tube.

The intensity of light is converted into a voltage by a high resolution A/D (analog-to-digital) converter. The digitized signal and other variables are used by the CPU to compute the concentration using the above formula.

About every 2.5 seconds the M465L completes a measurement cycle consisting of a 1 second wait period for the sample tube to flush, followed by a 150 ms measurement of the UV light intensity to obtain I. The sample valve is switched to admit scrubbed sample gas for 1 second, followed by a 150 ms measurement of the UV light intensity to obtain I<sub>0</sub>. Measurement of the I<sub>0</sub> every 2.5 seconds eliminates instrument drift due to changing intensity of the lamp caused by aging and dirt.

## 3.2. Oxygen Sensor

The oxygen sensor (Figure 3-1) is actually a hybrid fuel cell: an electrochemical oxygen transducer that transforms oxygen to power in the 1 to 200 microwatt range. Of this fuel cell's three main components, an anode, a cathode, and an electrolyte, the cathode is the sensing electrode – the site where oxygen is reduced by the following reaction where four electrons combine with one oxygen molecule (in the presence of water from the electrolyte) to produce four hydroxyl ions:



**Equation 3-2. Reaction 1: Cathodic Half-reaction**

This cathodic half-reaction occurs simultaneously with the following anodic half reaction:



**Equation 3-3. Reaction 2: Anodic Half-Reaction**

The anode (lead) is oxidized (in a basic media) to lead oxide, and in the process two electrons are transferred for each atom of lead that is oxidized. The sum of the two half-reactions results in the overall reaction:



**Equation 3-4. Reaction 3: Overall Reaction**

### 3.2.1. Construction

The fuel cell, ~ 1.25" diameter and .75" thickness, is designed as a unit that can be discarded when the lead anode is consumed due to the sensing of oxygen. The cell is, therefore, maintenance-free, requiring no replacement of membranes or electrolyte and no cleaning of electrodes.

The rear of the cell is fitted with a contact plate composed of two concentric metal foils which are electrically common to the anode and cathode, and mate to spring loaded contacts in the various cell holding devices used throughout the product line. Inside the contact plate is a flexible membrane that accommodates internal volume changes. Another membrane, the sensing membrane which is made of Teflon of very accurately controlled thickness, covers the cathode. Between the two membranes is a space filled with **electrolyte** (an aqueous solution), which bathes all surfaces of the anode and cathode in a common pool of electrolyte.

The **anode** is composed of lead and is configured in such a manner (proprietary) so as to maximize the amount of metal available for reaction. The **cathode** is a convex metal disc approximately .75" in diameter with numerous perforations to facilitate continued wetting of the upper surface with electrolyte and assure minimum internal resistance during the oxygen sensing reaction. The external surfaces of the cathode are plated with an inert or noble metal.

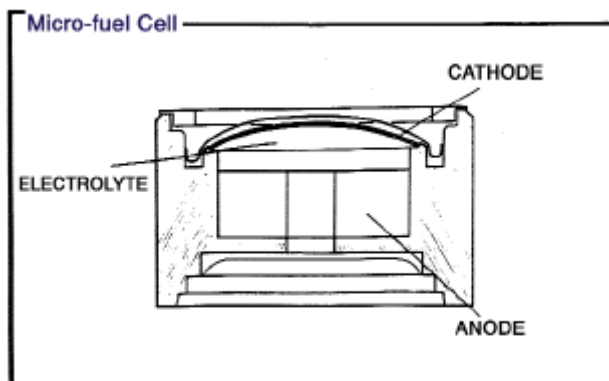

**Figure 3-1. Fuel Cell Transducer**

The main body of the cell is fabricated from high density polyethylene. This results in an oxygen sensor that can be placed in virtually any atmosphere or sample stream, protecting the components of the sampled media from reaction with the cell assembly.

### 3.2.2. Oxygen Measurements

In the cathodic half-reaction (Equation 3-1), four electrons are transferred for each oxygen molecule undergoing reaction. The oxygen molecule undergoes reaction by diffusing through the both the sensing membrane and the electrolyte between the sensing membrane and the upper surface of the cathode. The rate at which oxygen molecules reach the surface of the cathode determines the electrical output. This rate is directly proportional to the concentration of oxygen in the gaseous mixture surrounding the fuel cell. No oxygen produces no output.

This page intentionally left blank.

## 4. GETTING STARTED

---



### WARNING! – RISK OF DEATH OR SERIOUS INJURY!

To reduce the risk of death or serious injury from a chemical/combustion explosion hazard due to flammable gases/vapors/liquids, never allow contaminants to enter monitor during installation or use. The combination of ozone and the catalytic ozone destruct media in the monitor can produce strong oxidation reactions. Never allow organic contaminants, including but not limited to peroxides and chlorates, into monitor.

Upon receiving the Model 465L please do the following:

1. Verify that there is no apparent shipping damage. (If damage has occurred please advise shipper first, then Teledyne API.)
2. Allow at least a 1-inch clearance for proper ventilation.
3. Connect sample inlet line(s) to the SAMPLE INLET (Figure 4-3).  
**NOTE:** Sample tubing made from an inert material such as Teflon should be used to minimize sample degradation.



### CAUTION

Connect the exhaust fitting (Figure 4-3) to a suitable vent outside the monitor area.

4. Ensure that there are no communication devices connected until after start-up is complete.



### WARNING: Electrical Shock Hazard

**DISCONNECT POWER TO THE AC MAINS BEFORE MAKING OR REMOVING ANY ELECTRICAL CONNECTIONS TO THE INSTRUMENT.**

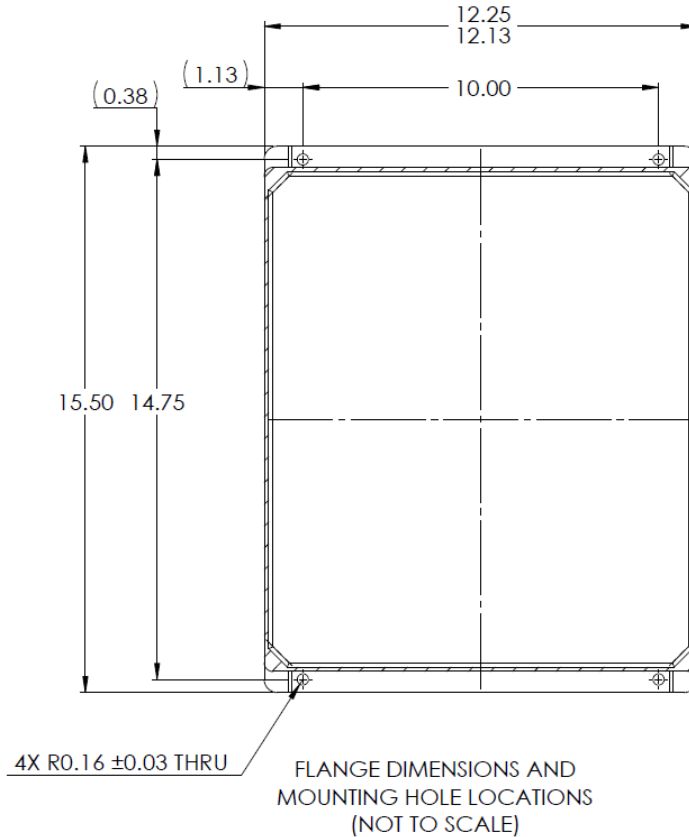

ALL TOLERANCES  $\pm 0.05$  UNLESS OTHERWISE STATED

**Figure 4-1: Mounting Hole Locations and Dimensions**

For wall-mount installation, the hole diameters are 0.32" (\*.128mm); bolt size should be 5/16" (8mm).

## 4.1. Wiring Requirements for NEMA Enclosures

Use appropriate wiring rated for this type of equipment, ensuring that it meets local and national safety and building requirements.

Ensure that overcurrent protection is used (a 5 A circuit breaker is recommended), and that it fulfills the following requirements:

- be located as near to the instrument as possible
- quickly and easily accessible
- clearly labeled as the disconnecting device for this instrument

## 4.2. Wiring Instructions

The electrical connection must be hard-wired to the 3-pin connector on the mainboard (Figure 4-2) labeled J23. AC power connection to the monitor should be made with 12-14 AWG stranded copper wire, connected to the monitor as follows:

- **Earth Ground (green):** Connect the earth ground wire to the screw terminal lug on the chassis as shown in the Figure below. **Do not** connect the earth ground wire directly to the PCB connector on the mainboard PCB.
- **Line (Black):** Connect the Line wire to the connector on the mainboard PCB labeled “Line”.
- **Neutral (White):** Connect the Neutral wire to the connector on the mainboard PCB labeled “Neutral”.

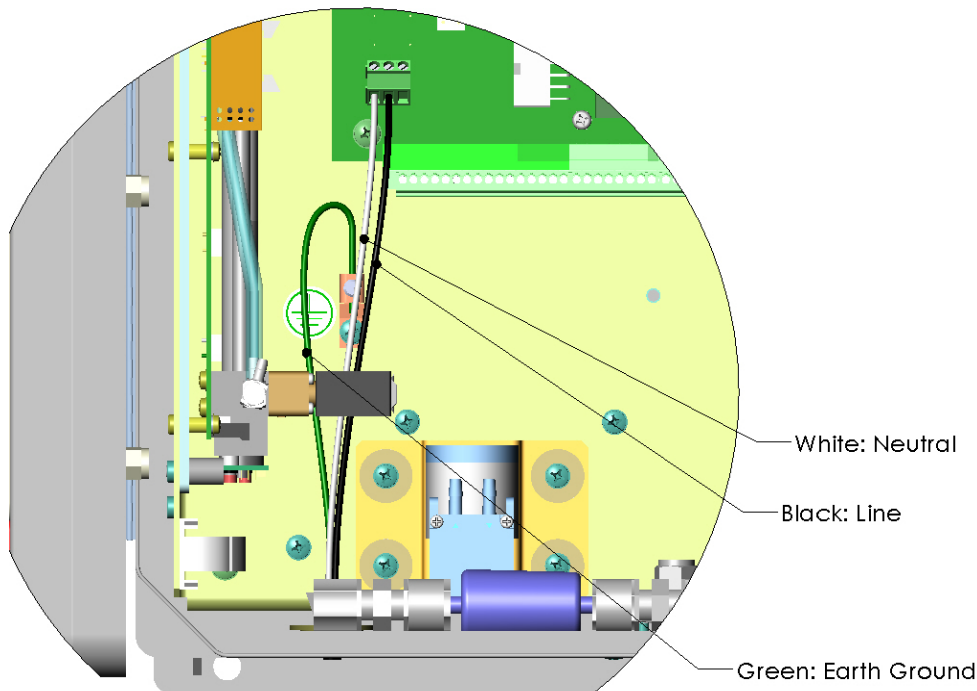

**Figure 4-2: AC Power Connection to Monitor**

1. Connecting the power cord to a power outlet will power on the unit. Ensure the power outlet is appropriate for the unit (see the serial number tag for correct voltage and frequency).

**WARNING: ELECTRICAL SHOCK HAZARD**



**VERIFY THAT THE INSTRUMENT IS SET UP FOR PROPER LINE VOLTAGE AND FREQUENCY. OBSERVE LOCAL ELECTRICAL CODES WHEN CONNECTING POWER TO THE MONITOR.**

2. Power on the unit. The front panel display should light with a sequence of messages, including the instrument serial number and software revision. (When the instrument first powers up, the display will show 'xxxx', indicating that the instrument is in start-up mode, waiting for the UV detector readings to stabilize)..
3. After the start-up period, the instrument will begin displaying the ozone concentration and the oxygen readings.



## 4.3. Pneumatic Connections

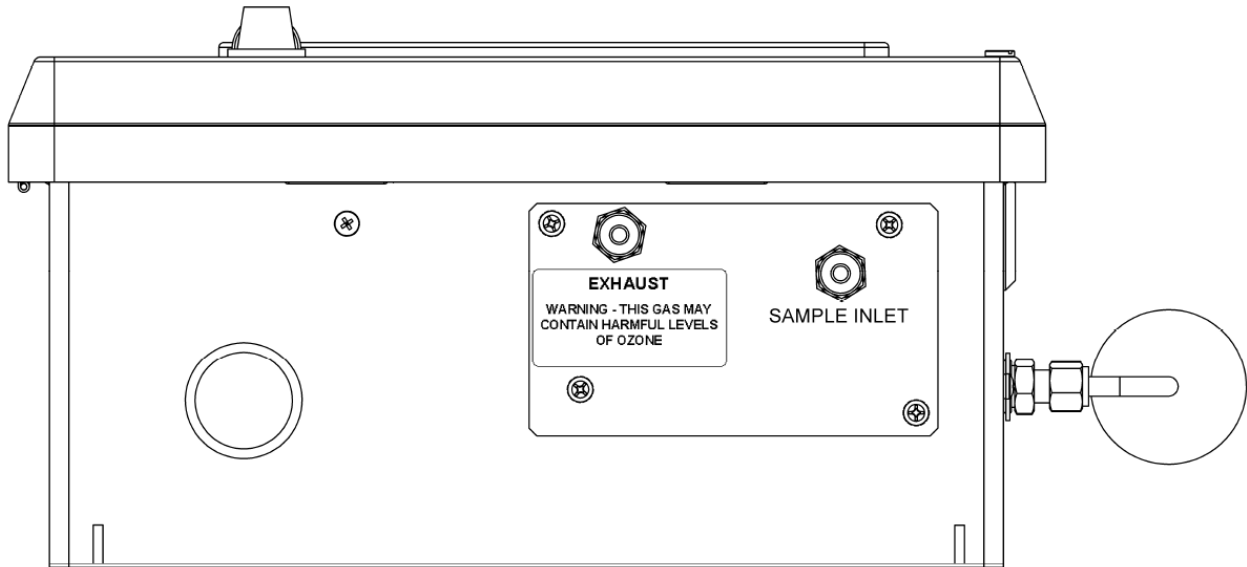

Figure 4-3: Pneumatic Connections

### 4.3.1. Sample Gas Connection

Sample gas connections are made to the 1/4" tube fittings on the rear panel. (See Figure 4-3)

1/4" O.D. FEP (Teflon™) tubing is recommended to connect the sample source to the monitor. Any fittings used in the sample lines should be constructed of stainless steel or Teflon™.

Teledyne API recommends that the length of tubing connecting the sample points to the monitor should be kept to 50 feet or less.

#### NOTE

For the sampling lines, use only 1/4" O.D. FEP tubing. For best analytical performance, the tubing should be pre-conditioned to ozone prior to installation to minimize ozone loss in the sampling lines. Pre-conditioned 1/4" FEP tubing is available from Teledyne API (Part number 02639)

### 4.3.1.1. Sample Filtration

The most important factor in maintaining an accurate and stable monitoring system for ozone is the cleanliness of entire pneumatic system leading up to (and including) the sensor assembly inside the instrument. Provision must be made for keeping dust and other particulate matter out of the monitor and upstream sample delivery tubing. The monitor is equipped with an internal particulate filter down-stream of the selector manifold.

In addition, it is recommended that inlet filters be installed at the inlet of the sample line. These filters should be constructed of PTFE or other inert material to avoid degradation of the ozone concentration. Appropriate disposable inlet filters can be purchased from TAPI. See the Spare Parts list in Appendix A of this manual for ordering information.

### 4.3.1.2. Sample System Design in Humid Environments

Care must be taken in the design of the sampling system to ensure that water vapor does not condense in the sampling lines or in the instrument itself. The sample lines should be routed to avoid large temperature gradients along the lines. If sample is brought in from a hot, humid area to a much cooler area, then low power heating tape should be wrapped around the lines to keep the temperature of the sample lines up and avoid condensation. The lines should also not have loops or low points where water could collect.

For applications that require sampling of very humid gas, a **Sample Conditioner** and/or a **Permeation Gas Dryer** may be required to lower sample gas humidity. A pneumatic block diagram with the locations of these M465L options is shown in Figure 4-4, followed by a description of each. Please contact the Teledyne API Sales Department for additional information.

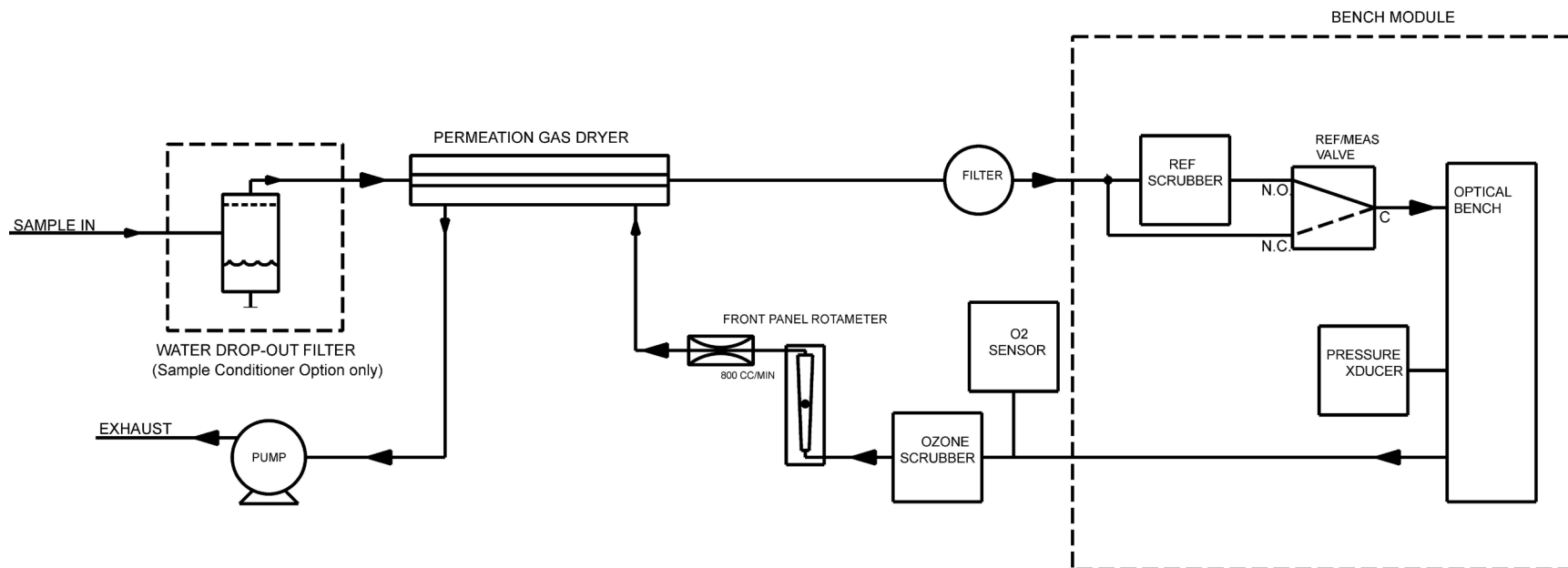

Model 465L+O<sub>2</sub> PNEUMATIC DIAGRAM

**Figure 4-4: Pneumatic Diagram with Sample Conditioner and Permeation Gas Dryer Options**

### Sample Conditioner Option

The Sample Conditioner option is a water drop-out filter and a permeation gas dryer, designed for high-humidity environments where the sampling gas has been saturated with water vapor and may contain small amounts of condensed water. This coalescing filter removes not only liquid, but also particulates with a Teflon filter element. Refer to Section 8.8 for maintenance procedures.

Due to the additional volume added by the water drop-out filter, there is an exception to the Response Time in the M465L specifications:

The Response Time of an M465L instrument equipped with the Sample Conditioner option, will be <60 seconds to 95%.

#### CAUTION



**The Sample Conditioner will NOT protect the unit from damage by large amounts of liquid, such as that ingested through immersion of the sample line.**

**Furthermore, it is important to closely track the amount of water accumulating in the Water Drop-out Filter after the monitor has been installed and running: if excessive condensation is occurring in the sample lines leading to the monitor, then heat-traced lines should also be used to minimize condensation**

The Sample Conditioner option includes a Permeation Gas Dryer, which is available as an alternate option (described next) if humidity is the only concern and there is no risk of condensation.

### Permeation Gas Dryer Option

The Permeation Gas Dryer serves to remove water vapor from sampling gas in a humid environment. It is an alternative option when there is no risk of condensation. The permeation material is a Teflon Type compound and has only a minimal effect on the ozone concentration in the sample stream. When the M465L is equipped with this option, the unit has been calibrated at the factory to compensate for any ozone loss in the permeation dryer.

### 4.3.2. Exhaust Connection

Connect a ¼” OD vent line to the “Exhaust” fitting on the rear panel. This line must be vented outdoors or to an appropriate discharge system capable of handling ozone. Follow local regulations regarding the discharge of ozone to the atmosphere. Note that the monitor may be equipped with an internal ozone scrubber for removal of ozone from the exhaust stream. For safety reasons, the exhaust port must still be vented appropriately as described above.

### 4.3.3. Electrical Connections

Figure 4-5 illustrates the I/O connector locations.

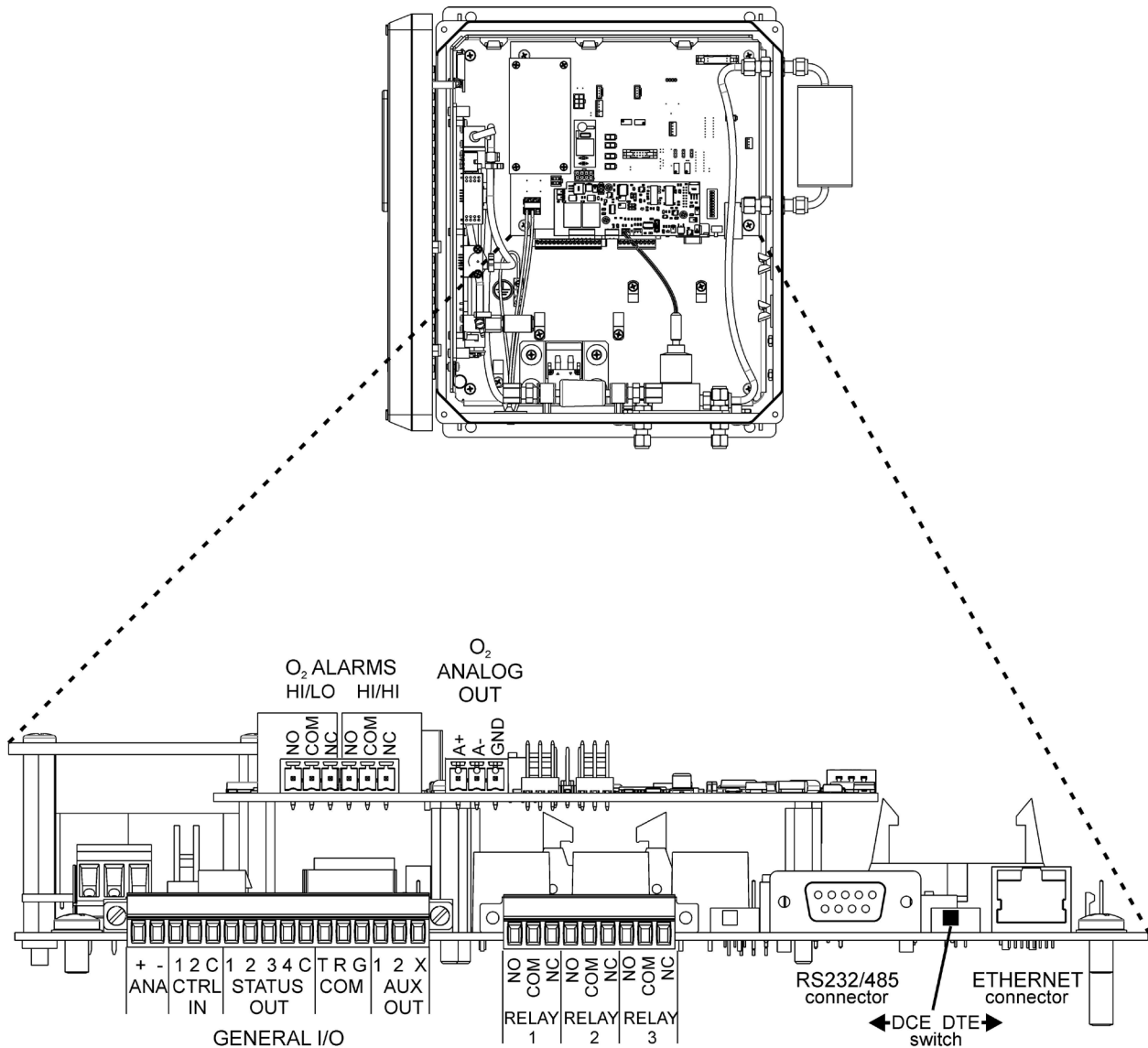

**Figure 4-5: Electrical I/O Connections**

### 4.3.4. Location of I/O Connectors

The I/O connectors are located internally in the instrument. Connection to these terminals is usually made via a conduit connection to the NEMA enclosure. A standard conduit penetration may be added to one of the walls of the enclosure for this purpose, or the existing penetration may be used.

### 4.3.5. Analog Output

The analog output is located at the GENERAL I/O connector and is labeled “ANA.” The analog output can be configured for 0-5V voltage or 4-20 mA current output. See Section 8.10 for details on verifying or changing the analog output hardware configuration.

The analog output is automatically scaled to the range of the instrument, i.e. if the monitor range is 1000 PPB, then 5V would correspond to 1000 PPB and 0V would correspond to 0 PPB. The ozone range can be changed through the SETUP>STREAM menu (Section 6.2.3.1). The oxygen range can be changed through the SETUP>O<sub>2</sub> menu (Section 6.2.3.3).

The M465L has an analog output step-test mode that can be used for verifying the operation of the analog output and calibration of external measurement equipment. This mode is described in Section 6.2.4.1.

### 4.3.6. Status Outputs

There are four instrument status outputs located at the GENERAL I/O connector. These status outputs mirror the state of the four diagnostic LEDs on the operation panel.

Electrically these outputs are SPST dry contact relay closures with a common contact, labeled ‘C’ on the connector panel. They are capable of switching up to 50 VDC, 250mA maximum current. There are no polarity requirements, so the outputs can be used to sink or source current from the ‘C’ pin, within the maximum voltage and current specified. Schematically, the outputs appear as shown in Figure 4-6 below:

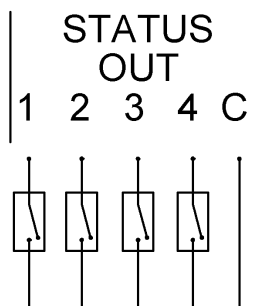

**Figure 4-6: Status Output Schematic**

The outputs are defined as follows:

**Table 4-1: Status Output Definitions**

Status Output #	Name	Normal Operating State
1	Sensor OK	On
2	Invalid Reading	Off
3	Check Lamp	Off
4	Pneumatic Error	Off

### 4.3.7. Hi-Current Relay Outputs

Three form C relay outputs are provided on the control board on the nine pin connector (Figure 4-5). The relays are labeled “Relay 1,” “Relay 2,” and “Relay 3.”

The relays are dry contact type form C (SPDT) relays with Normally Open (NO), Normally Closed (NC) and Common (COM) contacts. The relays are capable of driving loads of up to 250VAC, 5A. For maximum contact life, the relays should only be used to drive resistive loads. Contact life may be dramatically shortened if inductive loads are driven without any provision for minimizing high voltage “inductive kick” that can occur.

These relays have the following functions:

**Table 4-2: Relay Functions**

Relay #	Function	Normal Operating State
1	System OK Diagnostic	On
2	Hi/Lo Alarm	Off
3	Hi-Hi Alarm	Off

## 4.3.8. Digital Serial Interfaces

The communications ports available on the Model 465L can be configured as RS232, RS485 (Half Duplex,) or Ethernet (10Mbit.) This section provides only a brief overview of the digital serial connections. See Section 7 for more detailed information on configuring and using the digital serial interfaces.

### 4.3.8.1. RS232 Connection

With the instrument configured for RS232, connection can be made to the DB-9 connector, labeled “RS232/485”, or to the three “COM” pins on the GENERAL I/O connector. See Sections 7.2 and 7.3 for additional details.

When using RS232, a 9 pin serial cable can be used to connect the instrument to a standard PC (personal computer) serial port. TAPI can provide this cable; please see the spare parts list in Appendix A.

### 4.3.8.2. RS485 Connection

With the instrument configured for RS485, connection can be made to the DB-9 connector, labeled “RS232/485”, or to the three “COM” pins on the GENERAL I/O connector. See Sections 7.2 and 7.4 for additional details.

### 4.3.8.3. Ethernet Connection

With the instrument configured for Ethernet, connection should be made to the RJ-45 port labeled ETHERNET. Connection can be made using a standard Category 5 or better network patch cable. TAPI can provide an appropriate cable, please see the spare parts list in Appendix A. See Sections 7.2 and 7.5 for additional details.



## 5. OPTIONS

---

Following are descriptions of options available for the M465L.

### 5.1. Disposable Sample Inlet Filters

This option consists of 50 disposable filters for installation at the inlet end of all sample lines.

### 5.2. Electronic Flowmeter

The M465L can be fitted with an internal electronic flowmeter that enables the instrument to display the flow digitally on the front panel and provides a Pneumatic Error if the flow is outside its normal limits.

### 5.3. Sample Conditioner

For humid environments where there is risk of water condensation in the sample lines, this option serves to filter out liquid and particulates and includes a permeation gas dryer as well. For details Section 4.3.1.2.

### 5.4. Permeation Gas Dryer

This option removes water vapor from the sample stream in environments where humidity is a concern but where condensation is not a factor. For details Section 4.3.1.2.

this page intentionally left blank

# 6. OPERATION

## 6.1. Front Panel Overview

The M465L front panel display alternately shows ozone concentration currently being measured (O<sub>3</sub> LED lit) and the amount of oxygen sensed (O<sub>2</sub> LED lit). The front panel also has status LEDs and control buttons. See shows status of unit and alarms, and provides operational buttons to perform various functions (see Figure 6-1 below).

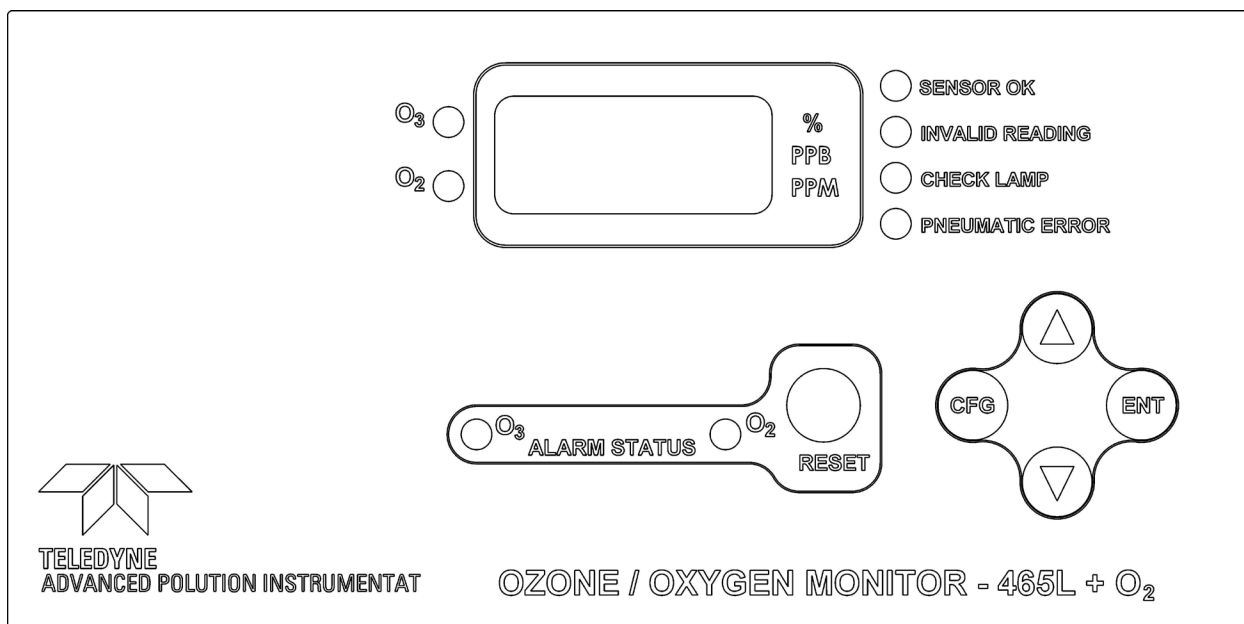

Figure 6-1: Front Panel Display

### 6.1.1. Gas Concentration Display

The 4-character LED display normally shows either the current oxygen reading or the current ozone concentration being measured by the M465L. While displaying O<sub>3</sub> concentration, one of the unit-of-measure indicators (PPM or PPB) should be backlit, indicating the current measurement units; while displaying the O<sub>2</sub> reading, the per cent (%) sign will be backlit. If none of these indicators are backlit, then the display is in Menu mode or Startup mode and is not displaying any readings. If the display is in Menu mode, the display can be returned to Concentration mode by repeatedly pressing the CFG button until one of the unit-of-measure indicators is lit. Note that even when the display is in Menu mode, normal measurement will continue in the background.

## 6.1.2. Menu Navigation Keypad

The menu navigation keypad (CFG, ENT and UP/DOWN buttons) is used to navigate the various menu items available on the M465L. The menus allow the user to view operational parameters of the instrument as well as view and modify the configuration of the instrument. See Section 6.2 for more detailed information.

## 6.1.3. Concentration Alarm Status/Reset

The M465L display and operation panel shows the alarm status of either the O<sub>3</sub> or the O<sub>2</sub> indicated by which corresponding LED is lit.

### NOTE

If the alarms are configured for latching operation, then the RESET button can be used to attempt to reset all alarms. Note that alarms can only be reset if the concentration measured has subsequently dropped below the alarm limit. If the alarms are configured for non-latching operation, they will be automatically cleared when the concentration falls below the alarm threshold. The RESET button has no effect when the alarms are configured for non-latching operation.

Access the alarm submenus through the VARS and O<sub>2</sub> menus (Figure 6-3 and Figure 6-4, respectively).

## 6.1.4. Status LEDs

There are four status LED's on the front panel to the right of the concentration display. These LED's provide a quick view of the instrument's status as well as an indication of any problems that may exist. The normal state for these LED's after the initial 20 minute warm-up period is as follows:

**Table 6-1: Status LED's**

Status LED	Normal State
Sensor OK	ON
Invalid Reading	OFF
Check Lamp	OFF
Pneumatic Error	OFF

If any of these LED's are in a different state than shown above, then some adjustment or troubleshooting should be performed. See Section 9.1 for more detailed information.

## 6.2. Front Panel Menus

The M465L has an interactive menu structure that can be operated from the front panel. From within this menu structure, the operator can view real-time parameters such as temperature and pressure, view configuration information, and edit setup parameters such as alarm limits.

Figure 6-2 below shows the menu structure as well as the buttons that are used to navigate it.

Starting with the display in Concentration mode, press **CFG** to enter Menu mode. At this point the unit-of-measure LED should turn off and the first level of the Menu tree will be active.

Pressing the **UP/DOWN** arrows will now select from the items available at this menu level.

Press **ENT** to enter one of these sub-menus or press **CFG** to back out of this menu level back to Concentration mode.

### 6.2.1. Menu Navigation Basics

1. Press **CFG** from Concentration mode to enter Menu mode.
2. Once in Menu mode, **CFG** will move backwards one level in the menu structure and **ENT** will move forward.
3. Each menu level contains an EXIT selection. Selecting EXIT and pressing **ENT** will exit the Menu mode and return the display to Concentration mode.
4. The Menu mode will timeout if no buttons are pressed within 30 seconds, and the instrument will automatically return to Concentration mode.

### 6.2.2. Editing Numeric Values

At certain places in the menu structure the operator can edit numeric values. The menu buttons behave somewhat differently when in this mode.

Press **CFG** to select a digit to edit. The selected digit will blink. Next press the **UP/DOWN** arrows to increment/decrement the selected digit. Press **CFG** again to select another digit. Pressing **CFG** at the last digit will wrap back to the first digit.

Once all the digits have been edited, press **ENT** to accept the new value.

To abort the editing process without changing the original value, press and hold the **CFG** button until the display returns to the previous menu level.

Note that limit checking is enforced while editing values and changes that would result in invalid values are ignored.

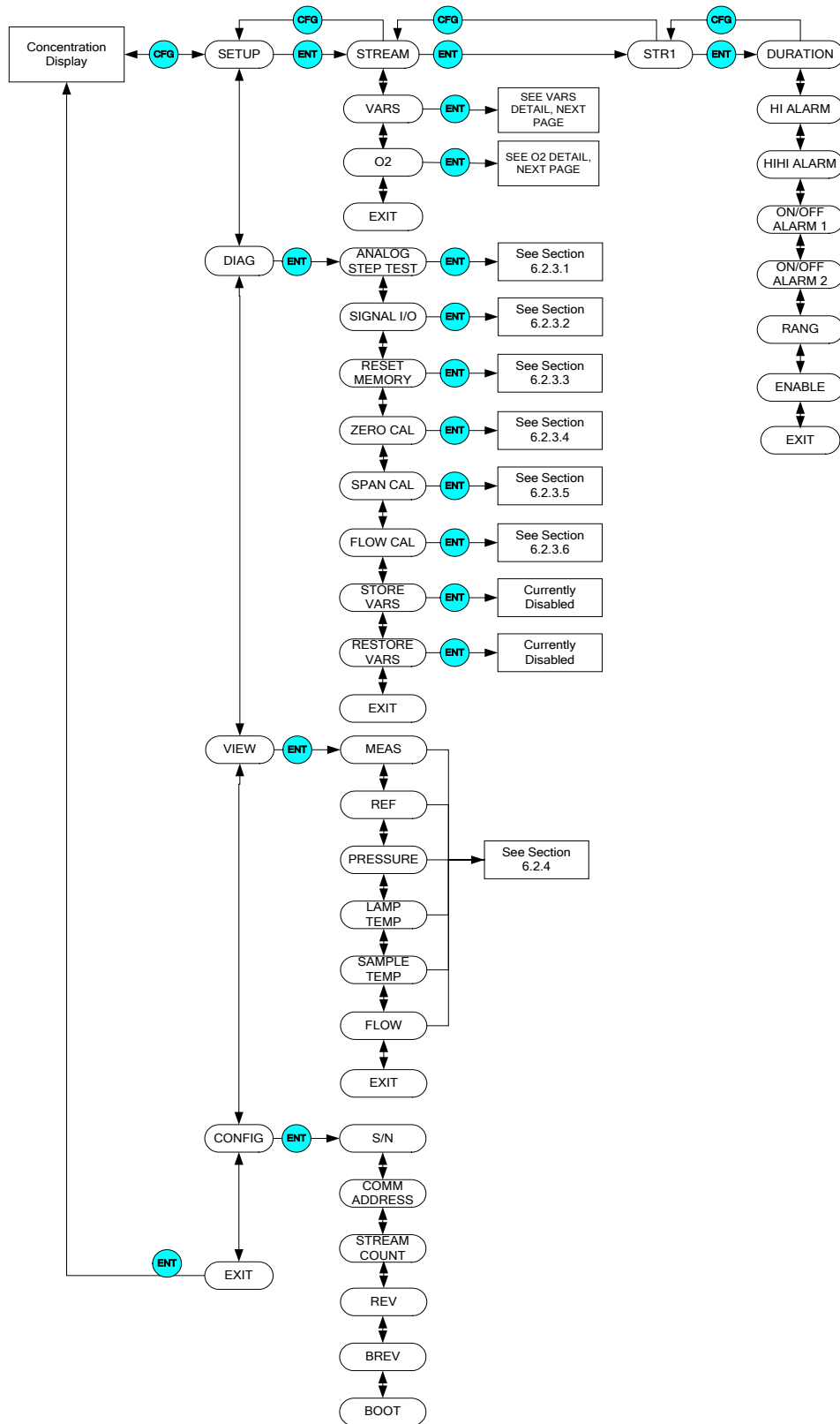

Figure 6-2: Front Panel Menu Diagram

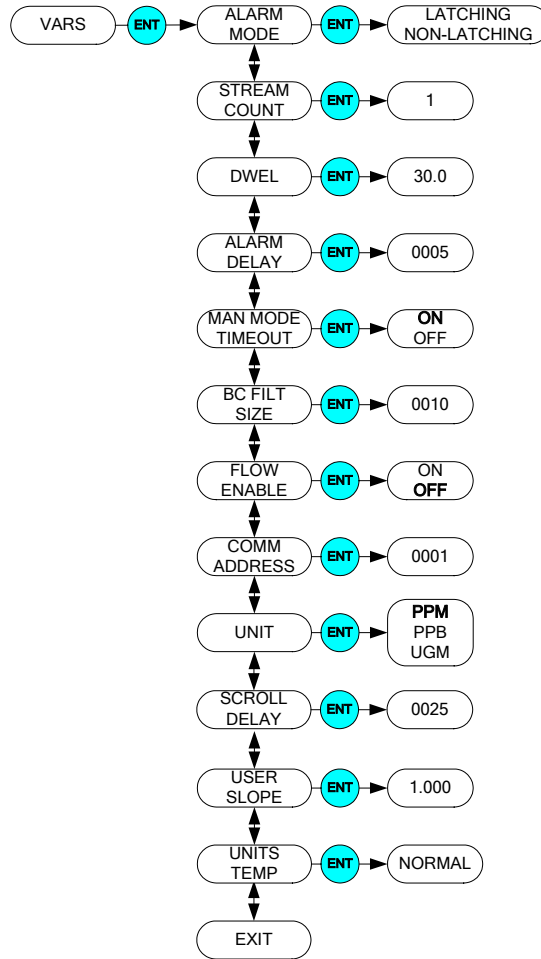

Figure 6-3: Front Panel Menu Diagram, VARS Menu Details

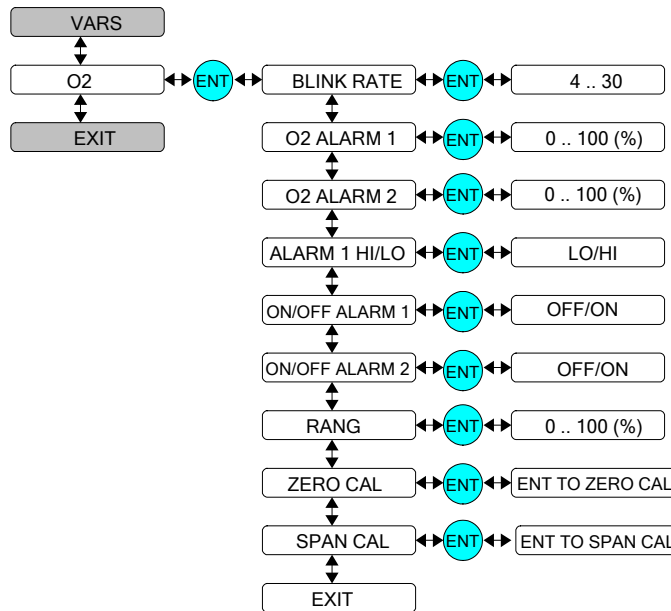

Figure 6-4: Front Panel Menu Diagram, O<sub>2</sub> Menu Details

## 6.2.3. SETUP Menu

The SETUP menu is used to set duration, alarms, ranges, and to set the parameters for the Variables (VARS) and for the O<sub>2</sub> sensor.

### 6.2.3.1. SETUP>STREAM

The STREAM menu allows the operator to view and edit properties of the measurement stream. The following properties are available:

**Table 6-2: STREAM Parameters**

Parameter	Meaning	Default Value	Range
DURATION	Sets measurement duration, which equals the time set in the menu minus the time set for dwell phase. (DWEL Var, Table 6-3).	60.0 Seconds	60.0 – 360.0 Seconds
HI ALARM	HI alarm trigger value	0.100 PPM	.010 – 9.999 PPM*
HIHI ALARM	HI-HI alarm trigger value	0.300 PPM	.010 – 9.999 PPM*
ON/OFF ALARM 1	HI alarm enable, enables HI alarm operation	ON	ON/OFF
ON/OFF ALARM 2	HI-HI alarm enable, enables HI-HI alarm operation	ON	ON/OFF
RANG	Concentration range for specified stream. Used to scale the analog output.	1.0 PPM	1.0 – 500.0 PPM
ENABLE	Allows the choice of viewing or skipping each stream in a multi-channel instrument when cycling through the streams in Auto or Manual modes. OFF = skip. At least one stream must be set to ON (enabled).	ON	ON-OFF

\* For low concentration instrument ranges. For certain range configurations, the alarms may be set to higher values



### 6.2.3.2. SETUP>VARS

The VARS menu allows viewing and editing of various global setup variables that effect how the M465L operates. These variables are stored in the instrument's non-volatile memory. Table 6-3 lists these variables and their respective functions.

**Table 6-3: VARS List**

VAR	Meaning	Default Value	Range
S/N	Serial number of M465L. This number should match the serial number tag on the rear of the instrument.	N/A	1 – 9999
ALARM MODE	Controls the latching behavior of the concentration alarms. See Section 6.1.3 for additional details.		LATCHING, NON-LATCHING
STREAM COUNT*	Refers to the one stream available in the instrument.	1	n/a
DWEL	Set period during which no readings are taken while sample gas is purged. Also see DURATION in Stream menu, (Table 6-2).	30.0 Seconds	0.0 – 30.0 Seconds
ALARM DELAY	Number of readings above alarm limit required to trigger alarms	5	1 - 10
MAN MODE TIMEOUT	Enables/disables the Manual mode timeout feature, which automatically returns the instrument to Auto mode when no keys are pressed for 10 minutes.	ON	ON, OFF
BC FILT SIZE*	Boxcar filter length for concentration filter. Increasing the size of the filter will smooth out the concentration readings but will also increase the response time.	10	1-30
FLOW ENABLE	Enables/disables operation of optional electronic flowmeter	OFF	ON, OFF
COMM ADDRESS	MODBUS address for serial communications	1	1 - 20
UNIT	Concentration unit-of-measure setting.	PPM	PPM, PPB
SCROLL DELAY	Inter-character delay for the front panel display, to increase speed (lower value) or decrease speed (higher value) the display scroll.	20	6-100
USER SLOPE	User-editable calibration slope value	1.000	0.8 – 1.0
UNITS TEMP	Standard (20°C) or Normal (0°C) temperature selection for g/Nm <sup>3</sup> units of measure.	NORMAL	NORMAL STANDARD

\* Changing the value of these VARS forces the instrument to automatically reboot for the changes to take effect.

### 6.2.3.3. SETUP>O<sub>2</sub>

The O<sub>2</sub> menu provides the ability to set several parameters as shown in Table 6-4.

**Table 6-4. O<sub>2</sub> Parameters**

Parameter	Meaning	Default Value	Range
BLINK RATE	Rate in seconds at which display alternates between O <sub>3</sub> and O <sub>2</sub> readings	3	3 - 30 Seconds
O <sub>2</sub> ALARM 1	HI alarm trigger value	17	0 – 100%
O <sub>2</sub> ALARM 2	HI-HI alarm trigger value	25	0 – 100%
ALARM 1 HI/LO	HI alarm enable, enables HI alarm operation	LO	LO/HI
ON/OFF ALARM 1	HI alarm enable, enables HI alarm operation	ON	ON/OFF
ON/OFF ALARM 2	HI-HI alarm enable, enables HI-HI alarm operation	ON	ON/OFF
RANG	Concentration range for specified stream. Used to scale the analog output.	21%	0 – 100 %
ZERO CAL	Calibrate the O <sub>2</sub> offset factor	0.0	0.0-100.0
SPAN CAL	Calibrate the O <sub>2</sub> slope factor	1.0	0.5-1.5

#### Zero Calibration of the O<sub>2</sub> Sensor

The zero calibration allows the instrument to calibrate its internal oxygen sensor offset factor. This should only be done with a source of zero air (free of oxygen, such as N<sub>2</sub>) connected to the “Sample In” port of the M465L. Allow the instrument to stabilize on the zero air source before attempting to zero. This normally takes 10-15 minutes.

When entering the O<sub>2</sub> Zero Calibration menu, the prompt “ENT TO CAL” appears on the display. Simply confirm the calibration by pressing the **ENT** button to perform the calibration (to abort the calibration, press the **CFG** button to return to the previous menu level.) After pressing **ENT**, the instrument will automatically exit the menu mode and return to Concentration mode. The concentration reading should quickly go to zero.

#### Span Calibration of the O<sub>2</sub> Sensor

The span calibration allows the instrument to calibrate its internal slope factor based on a known oxygen concentration. This should be done with a source of oxygen span gas connected to the

“Sample In” port of the M465L. Allow the instrument to stabilize on the span gas source for a minimum of 1 hour before performing the span calibration.

After the instrument has stabilized on the source of span gas, navigate to the O<sub>2</sub> Span Cal menu (Figure 6-5) and Press **ENT**. Next enter the Span Target concentration (the actual concentration of oxygen being supplied to the monitor) and press **ENT**. The display will next show a confirmation menu, **ENT TO SPAN**. Press **ENT** to perform the Span Calibration, or **CFG** to abort back to the start. If the calibration is successful, the display will return to the concentration menu and the monitor reading should adjust to read very close to the target value. If the calibration cannot be performed, an **OUT OF RANGE** error will be displayed. Press **ENT** to confirm and the display will return to the start of the O<sub>2</sub> Span Cal menu.

If the **OUT OF RANGE** error occurs, it means the Span Cal cannot be performed because it would result in an out of range slope value for the monitor. This means that either the sensor in the monitor is malfunctioning, causing improper readings, or the actual oxygen concentration being supplied to the monitor is different than the target value being entered.

## 6.2.4. DIAG Menu

The DIAG menu (Figure 6-2) contains functions that are useful for testing and configuring external equipment that may be connected to the General I/O connector on the control board (Figure 4-5).

### 6.2.4.1. DIAG>Analog Step-Test

When placed in this mode, the instrument will automatically step the analog output through 5 points from 0 to 100 % and display the current value on the front panel (see Section 4.3.5 for details on the analog output connection). The operator can suspend the automatic cycling and manually control the stepping by pressing either one of the **UP / DOWN** arrow buttons. To resume automatic cycling, exit the function by pressing **CFG** and re-enter by pressing **ENT**.

The 5 points will correspond to the following analog output values depending on whether the output is configured for 0-5V or 4-20mA:

**Table 6-5: Analog Step Test Values**

Point	0-5V Output	4-20 mA Output
0%	0.00 V	4 mA
25%	1.25 V	8 mA
50%	2.50 V	12 mA
75%	3.75 V	16 mA
100%	5.00 V	20 mA

Press **CFG** to exit from the Analog Step-Test function.

## 6.2.4.2. DIAG>Signal I/O

The Signal I/O menu allows the operator to manually control the various relay outputs and control inputs available. This function is useful for testing or debugging external control systems (i.e. dataloggers or PLC's) to which the instrument may be connected.

See Section 4.3.3 for additional details on making connections to these I/O signals. See Figure 6-2 for additional details for entering the Signal I/O menu.

**Table 6-6: Signal I/O List**

Signal Name	Control Board Label	Function
AUX 1 IN	CTRL IN - 1	UNDEFINED
AUX 2 IN	CTRL IN - 2	UNDEFINED
RELAY 1	RELAY 1	SENSOR OK
RELAY 2	RELAY 2	O <sub>3</sub> HI ALARM
RELAY 3	RELAY 3	O <sub>3</sub> HI-HI ALARM
STAT OUT 1	STATUS OUT - 1	SENSOR OK
STAT OUT 2	STATUS OUT - 2	INVALID READING
STAT OUT 3	STATUS OUT - 3	CHECK LAMP
STAT OUT 4	STATUS OUT - 4	PNEUMATIC ERROR
STAT AUX 1	AUX OUT - 1	UNDEFINED
STAT AUX 2	AUX OUT - 2	UNDEFINED
XRELAY 1	N/A	UNDEFINED
XRELAY 2	N/A	UNDEFINED
XRELAY 3	N/A	UNDEFINED
XRELAY 4	N/A	UNDEFINED
XRELAY 5	N/A	UNDEFINED
XRELAY 6	N/A	UNDEFINED
XRELAY 7	N/A	UNDEFINED
XRELAY 8	N/A	UNDEFINED
XRELAY 9	N/A	UNDEFINED
XRELAY 10	N/A	UNDEFINED
XRELAY 11	N/A	UNDEFINED
XRELAY 12	N/A	UNDEFINED
XRELAY 13	N/A	UNDEFINED
XRELAY 14	N/A	UNDEFINED
XRELAY 15	N/A	UNDEFINED
XRELAY 16	N/A	UNDEFINED

Signal Name	Control Board Label	Function
XRELAY 17	N/A	UNDEFINED
XRELAY 18	N/A	UNDEFINED
XVALVE 1	N/A	UNDEFINED
XVALVE 2	N/A	UNDEFINED
XVALVE 3	N/A	UNDEFINED
XVALVE 4	N/A	UNDEFINED
XVALVE 5	N/A	UNDEFINED
XVALVE 6	N/A	UNDEFINED

### 6.2.4.3. DIAG>Reset Memory

This function is currently disabled.

### 6.2.4.4. DIAG>Zero Cal

The zero calibration allows the instrument to calibrate its internal ozone offset factor (see Section 6.2.3.3 for calibration of the oxygen sensor). This should only be done with a source of zero air connected to the “Sample In” port of the M465L. Allow the instrument to stabilize on the zero air source before attempting to zero. This normally takes 10-15 minutes.

When entering the Zero Calibration menu, the prompt “ENT TO CAL” appears on the display. Simply confirm the calibration by pressing the **ENT** button to perform the calibration (to abort the calibration, press and hold the **CFG** button to return to the previous menu level.) After pressing **ENT**, the instrument will automatically exit the menu mode and return to Concentration mode. The concentration reading should quickly go to zero. Please note that while measuring zero air, a certain amount of noise or “dithering” of the concentration about the zero point will occur and is normal. This noise is typically 1-3 ppb (0.001 - 0.003 ppm) in magnitude.

## 6.2.4.5. DIAG>Span Cal

The span calibration allows the instrument to calibrate its internal slope factor based on a known ozone concentration. This should be done with a source of ozone span gas connected to the “Sample In” port of the M465L. Allow the instrument to stabilize on the span gas source for a minimum of 1 hour before performing the span calibration.

### NOTE

A Span Calibration should only be performed with a precision source of ozone calibration gas, such as a Teledyne API Model 700 or Model 703 calibrator. Simple ozone generators without a measurement feedback system should never be used for performing span calibrations.

If you are unsure regarding the suitability of a particular source of calibration gas, contact Technical Support at Teledyne API for assistance.

After the instrument has stabilized on the source of span gas, navigate to the Span Cal menu (Figure 6-5) and Press **ENT**. Next enter the Span Target concentration (the actual concentration of ozone being supplied to the monitor) and press **ENT**. The display will next show a confirmation menu, **ENT TO SPAN**. Press **ENT** to perform the Span Calibration, or **CFG** to abort back to the start. If the calibration is successful, the display will return to the concentration menu and the monitor reading should adjust to read very close to the target value. If the calibration cannot be performed, an **OUT OF RANGE** error will be displayed. Press **ENT** to confirm and the display will return to the start of the Span Cal menu.

If the **OUT OF RANGE** error occurs, it means the Span Cal cannot be performed because it would result in an out of range slope value for the monitor. This means that either the sensor in the monitor is malfunctioning, causing improper readings, or the actual ozone concentration being supplied to the monitor is different than the target value being entered.

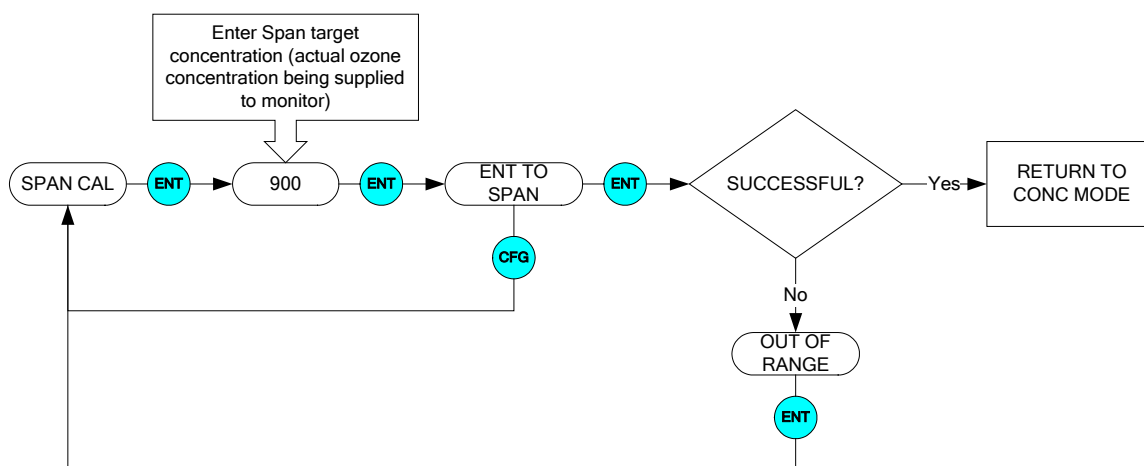
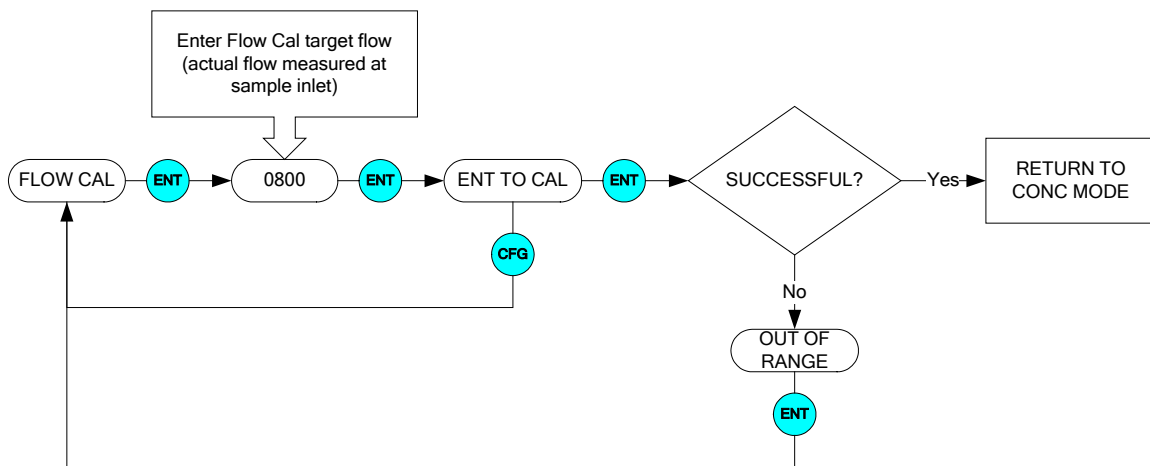

Figure 6-5: Span Cal Menu

### 6.2.4.6. DIAG>Flow Cal (Optional Electronic Flowmeter only)

The flow calibration allows the instrument to calibrate its internal flowmeter reading. This should be done with a calibrated flowmeter connected to the “Sample In” port of the M465L. Figure 6-6 below shows the Flow Cal menu. After the instrument has stabilized on the source of span gas, navigate to the Flow Cal menu (See Figure 6-2) and Press **ENT**. Next enter the Flow Cal target (the actual flow as measured at the sample inlet) and press **ENT**. The display will next show a confirmation menu, **ENT TO CAL**. Press **ENT** to perform the Flow Calibration, or **CFG** to abort back to the start. If the calibration is successful, the display will return to the concentration. If the calibration cannot be performed, an **OUT OF RANGE** error will be displayed. Press **ENT** to confirm and the display will return to the start of the Flow Cal menu.

If the **OUT OF RANGE** error occurs, it means the Flow Cal cannot be performed because it would result in an out of range flow slope value for the monitor. This means that either the flow sensor in the monitor is malfunctioning, causing improper readings, or the actual flow is different than the target value being entered.



**Figure 6-6: Flow Cal Menu**

### 6.2.4.7. DIAG>STORE VARS

This function is currently disabled.

### 6.2.4.8. DIAG>RESTORE VARS

This function is currently disabled.

## 6.2.5. VIEW Menu

The VIEW menu allows the operator to view various measurement parameters in real-time. This can be useful for diagnosing various instrument or system problems.

Note that these values are updated in real-time as they are repeatedly scrolled on the display.

**Table 6-7: VIEW Menu Parameters**

Parameter	Meaning	Units	Normal Range*
MEAS	UV detector reading, measure cycle	mV	250 – 1230
REF	UV detector reading, reference cycle	mV	250 – 1230
PRESSURE	Sample pressure	psia	9.0 – 14.9
LAMP TEMP	UV lamp temperature	°C	50.0 – 52.0
SAMPLE TEMP	Sample temperature	°C	5.0 – 50.0
FLOW	Sample Gas Flow Rate	cc/min	640 – 960
*After initial 20 minute warm-up period.			

## 6.2.6. CONFIG Menu

The CONFIG menu displays specific information related to the instrument's configuration. No changes are made within this menu.

**Table 6-8: CONFIG Menu Parameters**

Parameter	Meaning
S/N	Serial number of M465L. (Should match the serial number tag on the rear panel of the instrument).
COMM ADDRESS	Displays the MODBUS slave ID for the instrument.
STREAM COUNT	Always displays 1.
REV	Revision of instrument firmware
BREV	Revision of sensor firmware
BOOT	Revision of bootloader firmware



# 7. DIGITAL COMMUNICATIONS

---

## 7.1. Digital Communications Overview

The M465L comes equipped with a digital communications (Com) port that can be connected to a computer or digital data acquisition system. This Com port uses the standardized MODBUS® protocol and can be configured for RS232, RS485, or Ethernet (10 Mbit,) allowing for connections to a wide variety of devices and networks. See Section 7.2 for more information on configuring the Com port.

The Com port can be used for data acquisition, alarm triggering, and instrument configuration. All the functions that are available at the front panel of the instrument can also be performed over the Com port.

### NOTE

MODBUS Interface Software is available for download from the TAPI website. Other TAPI software, such as APICom, does not currently support communications with the M465L.

## 7.2. Changing Com Port Hardware Configuration



### WARNING - RISK OF ELECTRICAL SHOCK

**HIGH VOLTAGE MAY BE PRESENT WHEN POWER IS CONNECTED TO THE INSTRUMENT!**



**THE OPERATIONS OUTLINED IN THIS SECTION ARE TO BE PERFORMED BY QUALIFIED MAINTENANCE PERSONNEL ONLY!**

### NOTE

To avoid start-up problems, ensure that there are no devices attempting communication with the instrument during start-up. Once the sign-on message is displayed on the front panel, it is safe to begin communications.

The Com port can be configured for RS232, RS485, or Ethernet. To change the Com port hardware configuration, perform the following steps:

1. Disconnect power from the M465L.
2. Open the cover.
3. Locate the DIP switches labeled SW3 on the mainboard (Figure 7-1).
4. Turn ON the switches specified for the desired Com configuration (see Figure 7-2.) All other switches on SW3 should be OFF.
5. Locate SW2 (DTE-DCE switch, see Figure 4-5) on mainboard.

6. For RS-232 operation, set SW2 to either DTE or DCE (See Section 7.3.) For RS-485 operation, set SW2 to DCE.
7. Re-install the instrument cover.
8. Re-connect power to the instrument.
9. The software portion of the Com port configuration will now automatically be completed after the next instrument boot-up.

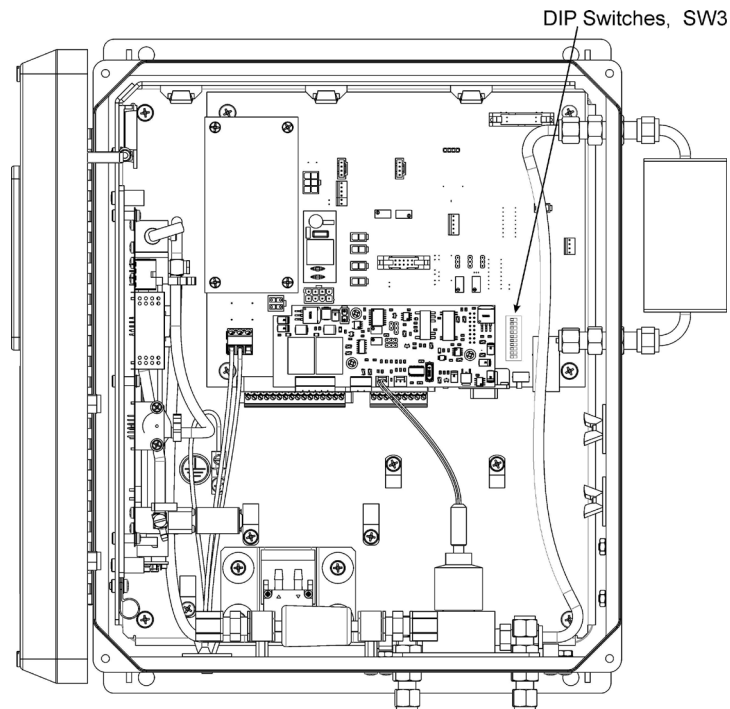

**Figure 7-1: DIP Switch Location (SW3)**

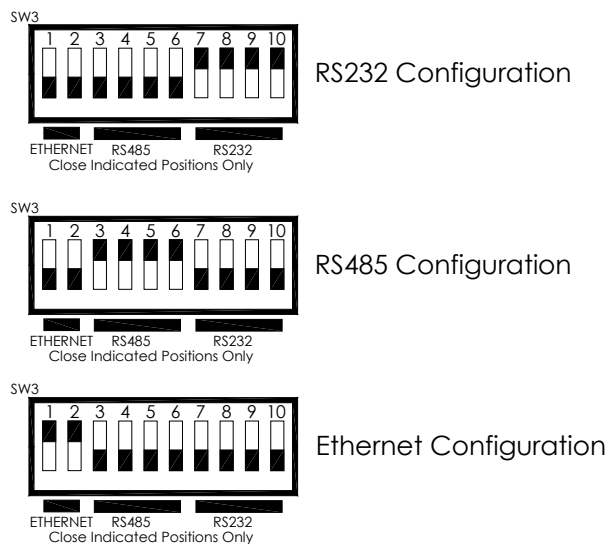

**Figure 7-2: Com Configuration Jumper Settings (SW2)**

## 7.3. RS-232 Configuration

The RS-232 configuration is usually used when making a one-to-one connection between the instrument and a single computer or PLC. The communications protocol used for the RS-232 configuration is MODBUS RTU. For details on the MODBUS RTU specification, please see <http://www.modbus.org/>.

With the instrument configured for RS-232, connection can be made to the DB-9 connector, labeled “RS232/485”, or to the three “COM” pins on the “General I/O” connector. Only one of these connections should be used, the other must be left un-connected. Table 7-1 below details the pinouts of these two connectors:

**Table 7-1: RS-232 Connector Details**

Function	DB-9 Connector Pin (SW2 – DTE)	DB-9 Connector Pin (SW2 – DCE)	General I/O Connector
Transmit (Tx)	3	2	‘T’
Receive (Rx)	2	3	‘R’
Ground	5	5	‘G’

Note that a DTE-DCE switch is provided so that the instrument can be connected to another device using either a straight-through or crossover (Null-Modem) cable. See Section 7.2 for details on changing this configuration.

The serial port setup for RS-232 configuration is shown in Table 7-2 below:

**Table 7-2: RS-232 Port Setup**

Property	Value
Baud Rate	57600
Data Bits	8
Parity	None
Stop Bits	1
Flow Control	None

## 7.4. RS-485 Configuration

RS-485 is commonly used for factory automation busses with a computer or PLC acting as a master. The communications protocol used for the RS-485 configuration is MODBUS RTU. For details on the MODBUS RTU specification, please see <http://www.modbus.org/>.

With the instrument configured for RS-485, connection can be made to the DB-9 connector, labeled “RS232/485”, or to the three “COM” pins on the “General I/O” connector. Table 7-3 below details the pinouts of these two connectors:

**Table 7-3: RS-485 Connector Details**

Function	DB-9 Connector Pin (SW2 – DCE)	General I/O Connector
RS485 - A	2	‘T’
RS485 - B	3	‘R’
Ground	5	‘G’

Note that for RS-485, the DTE-DCE switch should always be set to DCE. See Section 7.2 for details on changing this configuration.

The serial port setup for RS-485 configuration is shown in Table 7-4 below:

**Table 7-4: RS-485 Port Setup**

Property	Value
Baud Rate	57600
Data Bits	8
Parity	None
Stop Bits	1
Flow Control	None

## 7.5. Ethernet Configuration

Ethernet is commonly used for factory automation busses with a computer or PLC acting as a master. The communications protocol used for the Ethernet configuration is MODBUS TCP/IP. For details on the MODBUS TCP/IP specification, please see <http://www.modbus.org/>.

A Windows software application, *DeviceInstaller*, is available for configuring the Ethernet module used in the M465L. This application is available for download here:

<http://www.teledyne-api.com/software/>

### 7.5.1. Hardware Setup for Configuring the Ethernet Module

To make the first-time configuration of the Ethernet module as easy as possible, the module comes from the factory with DHCP enabled. The M465L can simply be plugged into a network with a DHCP server and an IP Address should be automatically assigned to, and stored in, the device.

A simple network can easily be constructed for this purpose by using a small broadband router commonly used for home networks. The M465L and a PC can then be connected to the router and the router's DHCP server will assign IP Addresses to both the PC and the M465L, enabling them to communicate.

### 7.5.2. Verifying Network Hardware Connection

With the M465L connected to a network and powered up, check the status of the two leds on the Ethernet connector on the rear panel. The left-hand LED should be lit; either amber or green indicating link status and the right-hand led should blink periodically, indicating activity on the network. See Table 7-5 below for more details on the status LED's.

If neither of the LED's are lit, then the Ethernet module may not be powered up or the instrument may not be connected to a valid network. Check the COM port configuration per Section 7.2 and make sure that it is set to "Ethernet."

**Table 7-5: Ethernet LED Definitions**

Link LED (Left Side)		Activity LED (Right Side)	
Color	Meaning	Color	Meaning
Off	No Link	Off	No Activity
Amber	10 Mbps Connection	Amber	Half-Duplex
Green	100 Mbps Connection	Green	Full-Duplex

### 7.5.3. Determining a Dynamically Assigned IP Address (DHCP Mode)

The *DeviceInstaller* software application (See Section 7.5) can be used to search a network for instruments and determine the IP Address assigned by a DHCP server.

1. Click **Start->Programs->Lantronix DeviceInstaller->DeviceInstaller**. If your PC has more than one network adapter, a message displays. Select an adapter and click **OK**.
2. Click on the **Search** icon. After a moment a list of instruments on the network will be displayed. The M465L should be listed as an **XPORT-IAP** type device.
3. Double-click on the device in the right-hand section of the *DeviceInstaller* window; a list of configuration parameters will be shown, including the IP Address. If multiple devices are shown, the correct one can be determined by matching the Hardware Address shown with the address printed on the label of the Ethernet module in the M465L. Note that the instrument cover must be removed to inspect this address in the instrument.

### 7.5.4. Manually Assigning a Static IP Address

For applications where the IP Address must remain constant, a static IP Address can be manually assigned to the instrument and the DHCP function must be disabled.

1. Click **Start->Programs->Lantronix DeviceInstaller->DeviceInstaller**. If your PC has more than one network adapter, a message displays. Select an adapter and click **OK**.

*Note: If the unit already has an IP address (e.g., DHCP has assigned an IP address), click the **Search** icon and select the unit from the list of Lantronix device servers on the local network.*

2. Click the **Assign IP** icon.
3. If prompted, enter the hardware address (on the product label) and click **Next**.
4. Select **Assign a specific IP address** and click **Next**.
5. Enter the **IP address**. The **Subnet mask** displays automatically based on the IP address; if desired, you may change it. On a local network, you can leave the **Default gateway** blank (all zeros). Click **Next**.
6. Click the **Assign** button and wait several seconds until a confirmation message displays. Click **Finish**.
7. Select the device from the main window list and select **Ping** from the **Tools** menu. The Ping Device dialog box shows the IP address of the selected unit.
8. From the **Tools** menu, click the **Ping** button. The results display in the Status window. Click the **Clear Status** button to clear the window so you can ping the device again.

*Note: If you do not receive "Reply" messages, make sure the unit is properly attached to the network and that the IP address assigned is valid for the particular network segment you are working with. If you are not sure, check with your systems administrator.*
9. Click the **Close** button to close the dialog box and return to the main window.

## 7.6. MODBUS Register Maps

### 7.6.1. MODBUS Commands Supported

Table 7-6 lists the MODBUS commands that are supported by the M465L. Note that the “Write” commands will only work with registers that are configured as Read/Write, see Section 7.6.4. The “Read” commands can be used with any register.

**Table 7-6: Supported MODBUS Commands**

<b>MODBUS Function Code</b>	<b>Description</b>
01	Read Coils
02	Read Discrete Inputs
03	Read Holding Registers
04	Read Input Registers
05	Write Single Coil
06	Write Single Register
15	Write Multiple Coils
16	Write Multiple Registers

### 7.6.2. Notes on MODBUS registers

Concentration values in the MODBUS registers are always expressed in units of PPB (parts-per-billion) for the O<sub>3</sub> sensor or in % for the O<sub>2</sub> sensor, regardless of the concentration units setting of the monitor.

### 7.6.3. Real-Time Concentration and Status Registers (Read Only)

Decimal Address	Description	Register Type	Start Bit	# Bits
1	Ozone Concentration (PPB)	Float Inverse	0	32
13	Ozone HI Alarm Status, 1= ON	Byte	0	8
16	Ozone HI-HI Alarm Status, 1= ON	Byte	0	8
19	Ozone Active Status, 1= Sampling	Byte	0	8
24	Gas Flow (cc/min)	Float Inverse	0	32
39	Sensor Reference Value (mV)	Float Inverse	0	32
41	Sensor Measure Value (mV)	Float Inverse	0	32
43	Sensor Pressure Value (psia)	Float Inverse	0	32
45	Sensor Gas Temperature (K)	Float Inverse	0	32
47	Sensor UV Lamp Temp (°C)	Float Inverse	0	32
50	O <sub>2</sub> in mV	Float Inverse	0	32
52	O <sub>2</sub> in %	Float Inverse	0	32
54	O <sub>2</sub> hi Alarm State	Byte	0	8
54	O <sub>2</sub> hihi Alarm State	Byte	8	8



## 7.6.4. Instrument Setup and Configuration Registers (Read / Write)

Decimal Address	Description	Register Type	Start Bit	# Bits
1031	Ozone Monitoring Duration (s)	Float Inverse	0	32
1043	Ozone HI Alarm Limit (PPB)	Float Inverse	0	32
1055	Ozone HI-HI Alarm Limit (PPB)	Float Inverse	0	32
1067	Ozone Analog Range (PPB)	Float Inverse	0	32
1079	Ozone HI Alarm Enable, 1=ON	Byte	0	8
1082	Ozone HI-HI Alarm Enable, 1=ON	Byte	0	8
1085	Alarm Latch Mode, 1= Latching, 0= Non-Latching	Byte	0	8
1131	Stream Enable (bits 0-5)	Byte	0	16
1132	O <sub>2</sub> % offset	Float	0	32
1134	O <sub>2</sub> % slope	Float	0	32
1136	O <sub>2</sub> hi Alarm	Float	0	32
1138	O <sub>2</sub> hihi Alarm	Float	0	32
1140	O <sub>2</sub> hi Alarm Enable	Byte	0	8
1140	O <sub>2</sub> hihi Alarm Enable	Byte	8	8

This page intentionally left blank.

## 8. MAINTENANCE AND ADJUSTMENTS

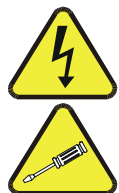

**WARNING - RISK OF ELECTRICAL SHOCK**  
**THE OPERATIONS OUTLINED IN THIS CHAPTER ARE TO BE PERFORMED BY QUALIFIED MAINTENANCE PERSONNEL ONLY!**

### 8.1. Maintenance Schedule



**CAUTION**  
**GENERAL SAFETY HAZARD**

**Do not look at the UV lamp while the unit is operating. UV light can cause eye damage. Always use safety glasses made from UV blocking material. (Generic plastic glasses are not adequate).**

Table 8-1 below outlines the suggested maintenance procedures and intervals for ensuring the M465L continues to operate accurately and reliably. These intervals are based on continuous (24 hours a day, 7 days a week) operation. These intervals may be lengthened for intermittent operation.

**Table 8-1: Maintenance Schedule**

Maintenance Item	Recommended Interval	Section
Replace internal particulate filter	6 months or monthly as applicable <sup>1</sup>	8.3
Adjust UV lamp	As Indicated by 'Check Lamp' LED or status output	8.4
Replace lamp	As required; when adjustment can no longer be performed.	8.5
Replace sample pump	2 years	8.6
Replace O <sub>3</sub> Sensor Module Valve	2 years	8.7
Replace O <sub>2</sub> sensor	1 year (or as necessary)	8.8
Water Dropout Filter (option)	As needed.	8.9
<sup>1</sup> When external sample line pre-filters are used. If pre-filters are not used, internal sample filter should be replaced every month.		

## 8.2. Instrument Layout



**WARNING - RISK OF ELECTRICAL SHOCK**

**HIGH VOLTAGE MAY BE PRESENT WHEN POWER IS CONNECTED TO THE INSTRUMENT!**

Figure 8-1 below shows the internal layout of the M465L. These figures will be referenced in the procedures that follow.

Note the caution areas where high voltage (line voltage) may be present when power is connected to the instrument.

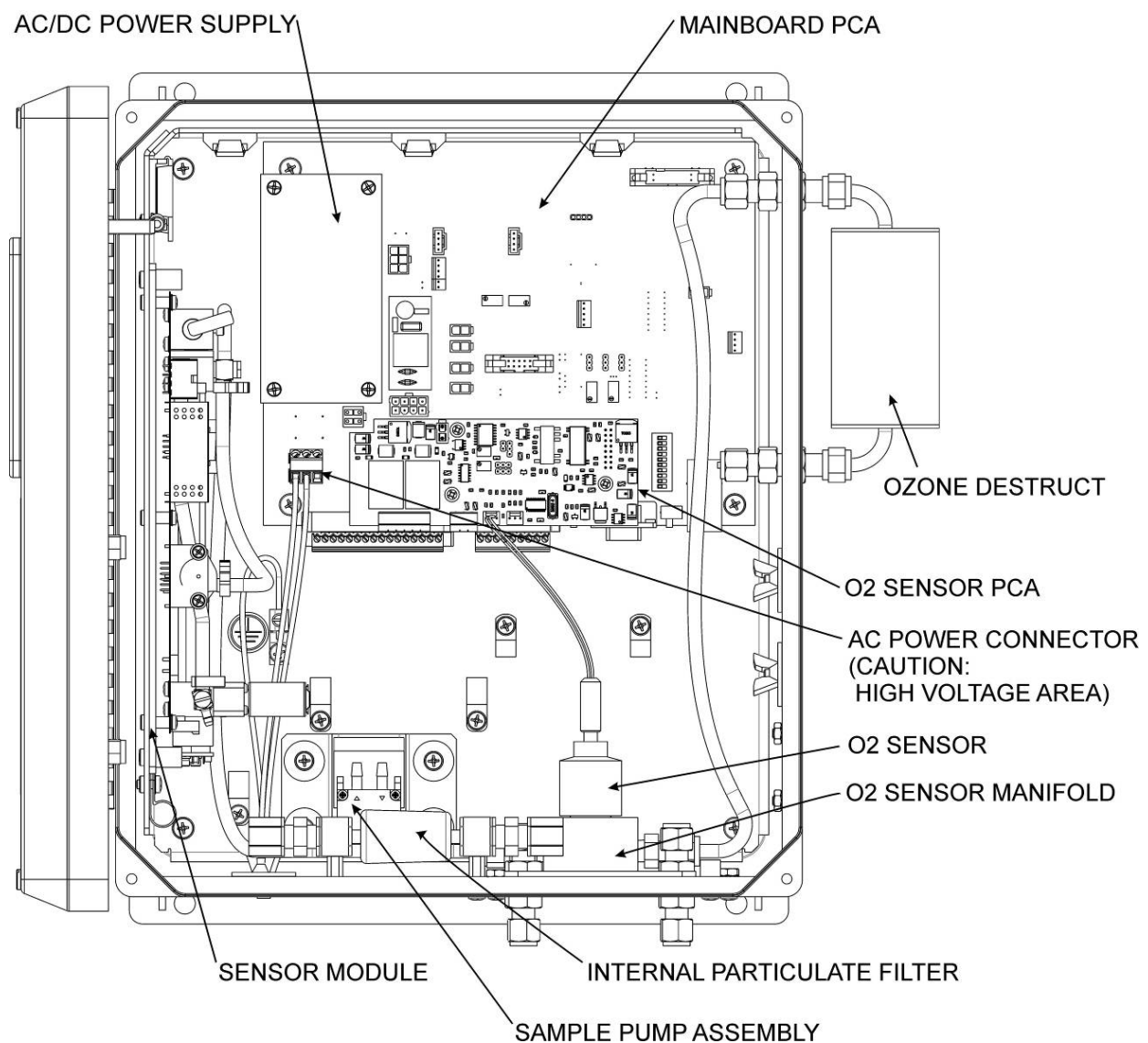

**Figure 8-1: Instrument Layout**

## 8.3. Replacing the Internal Particulate Filter

1. Disconnect power from the M465L.
2. Open the front panel.
3. Locate the filter (see Figure 8-1 above.) Un-strap the filter from the two plastic hold-down clamps. Note the arrow on the filter showing flow direction.
4. Loosen the two nuts holding the filter into the two union fittings.
5. Install the nuts on the new filter. Hand-tighten until snug, do not use tools.
6. Perform steps 3 through 1 in reverse to complete installation.

## 8.4. UV Lamp Adjustment



### CAUTION - GENERAL SAFETY HAZARD

Do not look at the UV lamp while the unit is operating. UV light can cause eye damage. Always use safety glasses made from UV blocking material. (Generic plastic glasses are not adequate).



### WARNING - RISK OF ELECTRICAL SHOCK

HIGH VOLTAGE MAY BE PRESENT WHEN POWER IS CONNECTED TO THE INSTRUMENT!

1. Instrument should be running and warmed up for at least 20 minutes.
2. With instrument running, navigate the front panel menu to VIEW menu and scroll to REF display and press **ENT**. At this point there should be a scrolling display similar to “REF = XXXX MV.” See Section 6.2 for details on menu navigation.
3. Locate the UV Detector adjustment pot on the forward end of the sensor module.
4. While observing the REF value on the display, slowly turn the pot to adjust the value. The target adjustment range is as high as possible within the range of **800 – 1150 mV**.
5. If the required adjustment cannot be achieved by adjusting the UV Detector pot alone, then additional adjustment can be made by loosening the two UV lamp setscrews on the UV lamp housing (see Figure 8-1) and rotating the lamp. Rotate the lamp very slowly while observing the REF value on the display. Make sure the lamp does not pull out and remains seated in the housing while it is being rotated. Re-tighten the two setscrews when a desired point has been reached.
6. If necessary, additional “fine tuning” can now be done with the UV Detector adjustment pot per step 5.
7. Re-Install instrument cover and observe REF value on display for a couple minutes to verify it does not drift out of the adjustment range.

## 8.5. UV Lamp Replacement



### CAUTION - GENERAL SAFETY HAZARD

Do not look at the UV lamp while the unit is operating. UV light can cause eye damage. Always use safety glasses made from UV blocking material. (Generic plastic glasses are not adequate).



### WARNING - RISK OF ELECTRICAL SHOCK

HIGH VOLTAGE MAY BE PRESENT WHEN POWER IS CONNECTED TO THE INSTRUMENT!

1. Disconnect power from the M465L.
2. Open front panel.
3. Loosen the two UV lamp setscrews on the UV lamp housing (see Figure 8-1 above for location.)
4. Unplug the lamp power cord from the connector labeled P1 on the sensor module.
5. Loosen the four slotted captive screws attaching the sensor module to the chassis.
6. Carefully slide the lamp out of housing. The sensor module may need to be raised slightly to completely remove the lamp.
7. Install the new lamp, seating it in the lamp housing until it stops.
8. Re-attach the sensor module captive screws to the chassis.
9. Re-tighten the two UV lamp setscrews.
10. Plug the lamp power cord into P1 on the sensor module.
11. Reconnect power to the instrument and turn on power switch. Let instrument warm up for at least 20 minutes.
12. Perform UV lamp adjustment procedure per Section 8.4.

## **8.6. Sample Pump Replacement**

1. Disconnect power from the M465L.
2. Open front panel.
3. Locate sample pump assembly.
4. Cut off the clamps holding the tubing to the pump nipples and remove tubing. Note which tubing is connected to inlet and outlet.
5. Unplug the pump power connector from the mainboard PCA at connector J12.
6. Remove the four screws attaching the sample pump assembly to the chassis.
7. Turn over pump assembly and remove the two screws holding the sheet-metal base to the pump.
8. Install the base on the new pump.
9. Install new pump assembly in chassis.
10. Reconnect tubing, note that outlet fitting of pump should be connected to tubing routed to the 'Exhaust' fitting on rear panel.
11. Re-install new tubing clamps or cable-ties to secure tubing connections.

## 8.7. O<sub>3</sub> Sensor Valve Replacement

1. Disconnect power from the M465L.
2. Open front panel.
3. Locate sensor module assembly (See Figure 8-1.)
4. Unplug the two-pin valve connector from the sensor PCA.
5. Remove the silver retainer clip from the top of the sensor valve. A pair of pliers may be used to slide off the retainer clip.
6. The valve coil can now be removed by sliding upwards.
7. Remove the two (2) mounting screws using a #2 Phillips screwdriver. See Figure 8-2. Note that there are four screw heads visible on the top of the valve body, only two (2) of these should be removed.
8. Remove valve body from sensor manifold.
9. Clean any residue or dirt off the surface of the manifold using a lint-free cloth and distilled or DI water.
10. Install the new valve by reversing steps 1-7. Note the proper orientation of the new valve as shown in Figure 8-2.

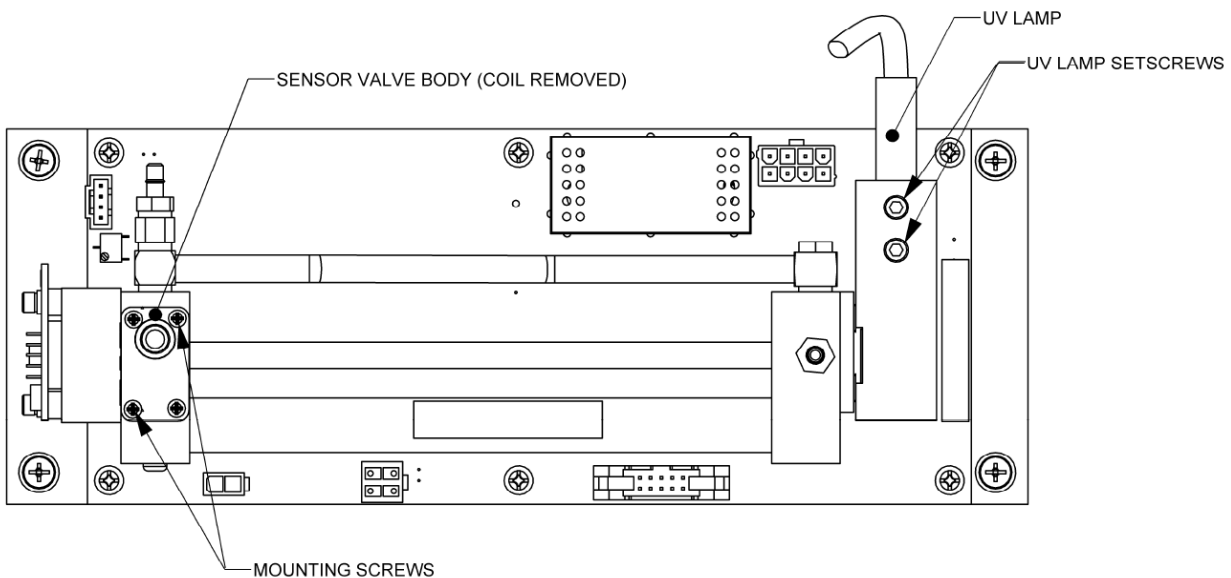

**Figure 8-2: O<sub>3</sub> Sensor Detail**



## 8.8. O<sub>2</sub> Sensor Replacement

The life of the Micro-fuel Cell is governed by the amount of lead anode material available inside per the rate at which it is consumed by the oxygen it senses. Typically, it should last about one year.

**IMPORTANT:**

**Do not remove replacement O<sub>2</sub> sensor from its storage bag until ready to install; exposure to air expends the sensor. Ensure that the airtight storage bag remains intact and sealed until time for replacement.**

To change the O<sub>2</sub> sensor:

1. Disconnect power from the M465L.
2. Open front panel.
3. Locate sensor module assembly (See Figure 8-1.)
4. Remove electrical cable.
5. Unscrew expended sensor from fitting and dispose according to local regulations.
6. Remove replacement sensor from storage bag and screw into fitting.

## 8.9. Water Drop-Out Filter (Option) Maintenance

Located externally on the right side of the enclosure, the Water Drop-Out Filter (Section 4.3.1.2) should be checked periodically for water build-up and drained. To drain this filter:

1. Disconnect the ozone supply line from the instrument.
2. Shut off flow to the instrument using the needle valve on the front panel.
3. Remove cap from the fitting located on the bottom of the filter and allow it to drain.
4. Replace cap and adjust flow to instrument.

Replacement of the particulate filter, a Teflon coalescing membrane should be rarely required. However, if it does become fouled, possibly indicated by a significant reduction in the gas pressure measured in the O<sub>3</sub> cell, which would trigger a warning in the instrument, replace it as follows:

1. Remove the orange cap from the top of the water drop-out filter.
2. Located the membrane on the underside of the cap assembly and replace it.
3. Tightly secure the orange cap back onto the water drop-out filter.

## 8.10. Configuring the Analog Output

The analog output can be configured for either 0-5V DC or 4-20mA operation. To change or verify the configuration of the analog output:

1. Disconnect power from the M465L.
2. Open front panel.
3. Locate the Mainboard PCA (see Figure 8-1 or Figure 8-3)
4. Set the desired operation as shown in Figure 8-3.
5. Re-secure the front panel.

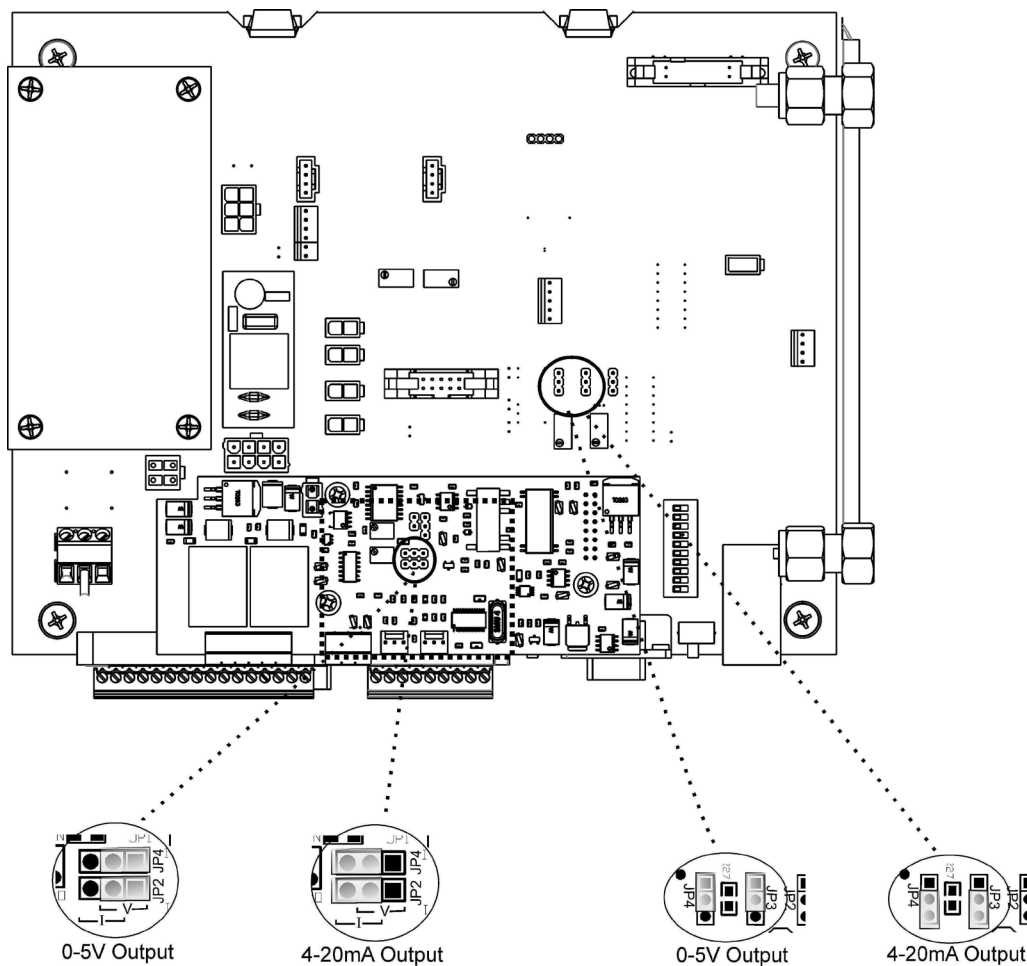

**Figure 8-3: Mainboard – Analog Output Configuration**

## 8.11. Cleaning Exterior Surfaces of the M465L

If necessary, the external case, the front panel mask and keyboard of the M465L can be cleaned with a damp cloth. Do not attempt to clean any of the other surfaces of the instrument. Do not submerge any part of the instrument in water or cleaning solution.

## 8.12. Boot Loader Operation

The main function of a boot loader is to load or update the firmware to the microcontroller on the Printed Circuit Board (PCB) of an instrument. There are two types of boot loader setup: hardware and software, described in the following sections.

### NOTE

When an external MODBUS host device is attempting to communicate with the instrument over the serial or Ethernet port while the instrument is starting up, the instrument may halt. In order to prevent the problem from occurring, ensure that there are no devices attempting communication with the instrument during start-up. Once the sign-on message is displayed on the front panel, it is safe to begin communications.

### 8.12.1. Boot Loader – Hardware Setup

Verify that the instrument is configured for an RS-232 connection. See Section 7.2 for details on changing the COM port configuration. The instrument can be connected to the PC COM port using a 9-pin serial cable (TAPI P/N WR77).

### 8.12.2. Boot Loader – Software Setup

Table 8-2 lists the required firmware loader software and firmware options.

**Table 8-2: Required Software**

SOFTWARE TYPE	FILE TYPE/VERSION
PC Software	FirmwareLoader.EXE
Instrument Firmware	05498-00_XX.HEX (for ppb, ppm, ugm)
	05498-01_XX.HEX (for ppb, ppm, pphm)

The firmware loader is available on Teledyne API's website at <http://www.teledyne-api.com/software/>.

1. Install the firmware loader software onto a PC.
2. Verify the cable connections. Do not power up the instrument.
3. Run the firmware loader application on the PC.
4. Select the COM port that the instrument is connected to.
5. Select the HEX file for the appropriate firmware.
6. Refer to Section 8.12.2.1 to upload the firmware or to Section 8.12.2.2 to verify the firmware.

### 8.12.2.1. Upload Firmware

1. Press "Write". The screen will display, "Wait for boot loader".
2. When the screen displays, "Power cycle instrument now", power up the instrument.

**NOTE**

Search for boot loader will time out in 20 seconds. If the instrument is not powered up in 20 seconds, the screen will display, "No boot loader detected." Go back to step 1 to rewrite the firmware.

The firmware loader software should display a message "Boot loader found, uploading...". If this message is not displayed, power down the instrument and recheck the COM port configuration and cable (see Section 8.12.1) and retry.

3. When the upload is complete, a message, "Write-flash completed successfully" should be displayed. If it is an unsuccessful upload, a message, "Write-flash error" is displayed. If a Write-flash error occurs, ensure that the correct PC COM port is selected for the instrument (see Section 8.12.2, step 4).

**NOTE**

It is not recommended to stop the writing process half way through. This will cause the firmware to not be fully uploaded.

## 8.12.2.2. Verify Firmware

The verify function compares the instrument's current firmware to the selected HEX file (see Section 8.12.2, step 5) and confirms whether or not the files are a match.

1. Press "Verify". The screen will display, "Wait for boot loader".
2. When the screen displays, "Power cycle instrument now", power up the instrument.

### NOTE

Search for boot loader will time out in 20 seconds. If the instrument is not powered up in 20 seconds, the screen will display, "No boot loader detected." Go back to step 1 to verify the firmware.

The firmware loader software should display a message "Boot loader found, verifying...". If this message is not displayed, power down the instrument and recheck the COM port configuration and cable (see Section 8.12.1) and retry.

3. When the upload is complete, a message, "Verify-flash completed successfully" should be displayed. If it is an unsuccessful upload, a message "Verify-flash error" is displayed. If a Verify-flash error occurs, ensure that the correct PC COM port is selected for the instrument (see Section 8.12.2, step 4).

### NOTE

A verification process can be stopped at any point in time. This will not affect the firmware that is already uploaded on the instrument. The instrument will automatically go to the firmware in 10 seconds.

This page intentionally left blank.

## 9. TROUBLESHOOTING

---

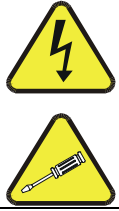

**WARNING** RISK OF ELECTRICAL SHOCK.

THE OPERATIONS OUTLINED IN THIS CHAPTER ARE TO BE PERFORMED BY QUALIFIED MAINTENANCE PERSONNEL ONLY!

### 9.1. Reference Drawings

The drawings contained in this section are for general reference and may be useful when performing certain troubleshooting activities.

#### 9.1.1. Interconnect Diagram

Figure 9-1 below details the electrical connections between the various electronic modules in the M465L.

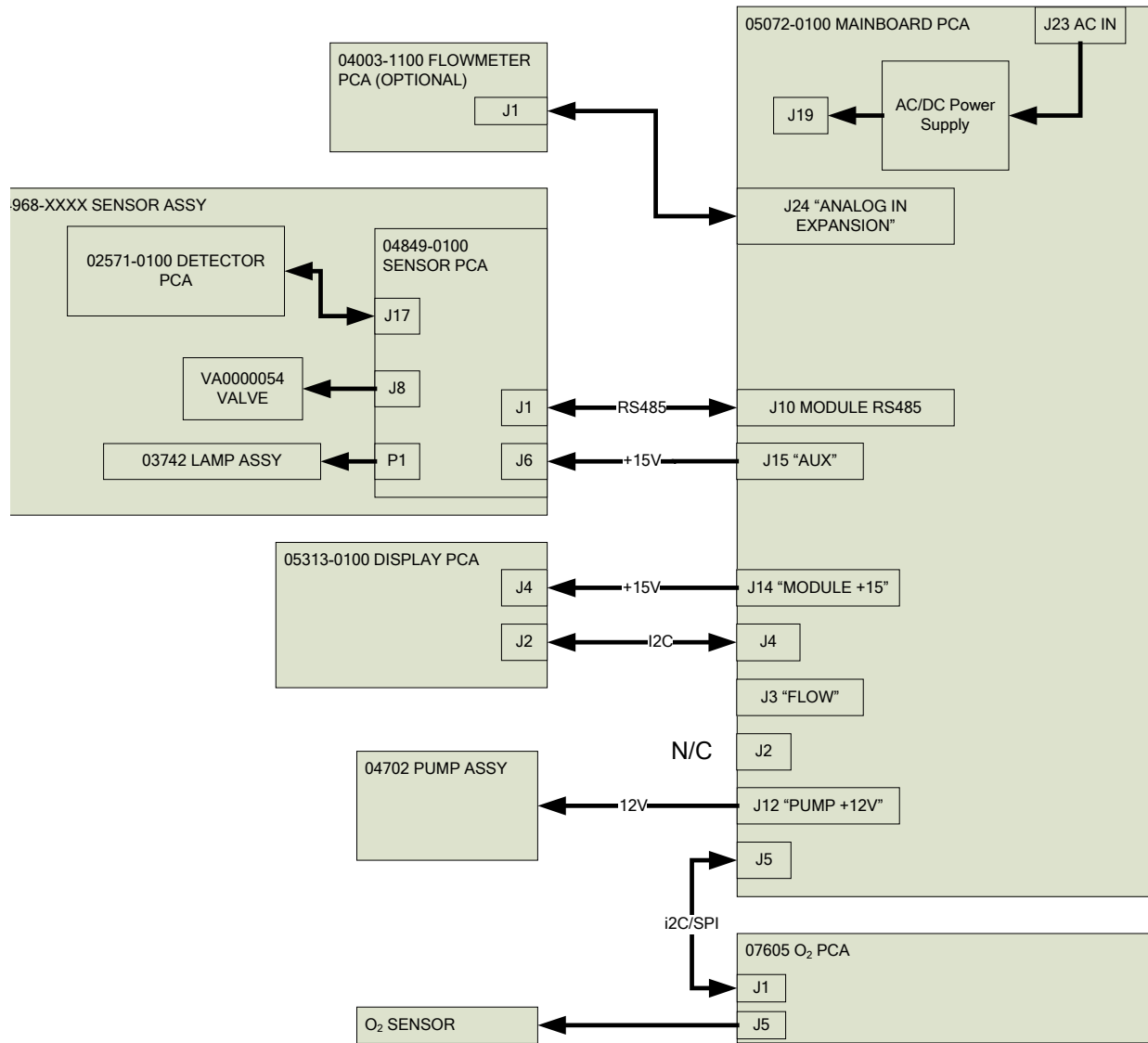

**Figure 9-1: Interconnect Diagram**

## 9.2. Troubleshooting by Front Panel Status LED's/Status Outputs

The M465L has 4 front-panel status LED's that reflect the current operating status of the monitor, and indicate fault conditions. There are also four relay Status Outputs inside the chassis (Figure 4-5) that reflect the state of these status LED's. See Section 4.3.6 for more information on the Status Outputs.

The Status LED's are categorized into Critical and Non-Critical warnings. Critical warnings are those that would normally require immediately removing the monitor from service and repairing



it. Non-critical warnings are those that indicate some maintenance would be useful, but not immediately required.

**Table 9-1: Status LED/Output Definitions**

Status Output #	Status LED Label	Normal Operating State	Triggers		Critical Warning?
			O <sub>3</sub> Sensor	O <sub>2</sub> Sensor	
1	Sensor OK	On	<ul style="list-style-type: none"> <li>• No bench communications</li> <li>• Reference &lt; 125.0 mV</li> <li>• Reference &gt; 1230.0 mV</li> </ul>	N/A	Yes
2	Invalid Reading	Off	<ul style="list-style-type: none"> <li>• O<sub>3</sub> Concentration &lt; -10.0 PPB</li> <li>• O<sub>3</sub> Concentration &gt; F.S. Range</li> </ul>	N/A	No
3	Check Lamp	Off	<ul style="list-style-type: none"> <li>• Reference &lt; 250.0 mV</li> </ul>	N/A	No
4	Pneumatic Error	Off	<ul style="list-style-type: none"> <li>• Pressure &lt; 9.0 psia</li> <li>• Pressure &gt; 14.9 psia</li> <li>• Flow &lt; 640 cc/min</li> <li>• Flow &gt; 960 cc/min</li> <li>• O<sub>2</sub> sensor not installed</li> </ul>		No

### 9.2.1. Sensor OK

The Sensor OK LED indicates the status of the O<sub>3</sub> sensor module in the monitor. The normal state of this LED (or Status Output) is On. If this LED remains off after the normal 20 minute warm-up period, then a failure has occurred and the monitor should be removed from service and repaired.

The most common cause of this warning is a failure of the UV Lamp. A UV Lamp Adjustment (See Section 8.4) should be attempted. If the UV Lamp cannot be adjusted to meet the specified values, then a UV Lamp Replacement should be performed (See Section 8.5.)

This warning can also be caused by a communications error with the sensor module. Inspect the two cables between the Mainboard PCA and Sensor Module for loose or intermittent connections (See Section 8.2 for monitor layout.) If no cable problem can be found, then the Sensor Module should be replaced.

### 9.2.2. Invalid Reading

The Invalid Reading LED indicates that the instrument is reading a value that cannot be represented properly on the analog output. Since the analog output is limited to 0-5V (or 4-20mA,) it cannot properly represent negative values, or values in excess of the full-scale range.

If the monitor is consistently reading negative values, then a zero calibration should be performed, see Section 6.2.4.4 (ozone monitor) or Section 6.2.3.3 (oxygen sensor).

If the monitor is consistently reading values in excess of the full-scale range, then the range value should be adjusted higher. See Section 4.3.5 for details on setting the range value.

### 9.2.3. Check Lamp

The Check Lamp LED indicates that the UV Lamp intensity has dropped below 250mV, a level where UV Lamp Adjustment (See Section 8.4) should be made at the next convenient opportunity. Note that this is a non-critical warning and immediate service is not required. However if the UV Lamp intensity drops below 125mV, then the Sensor OK LED will also turn off, indicating that the monitor must be immediately serviced or taken off-line.

### 9.2.4. Pneumatic Error

The Pneumatic Error LED indicates that one of the pneumatic parameters, flow or pressure, has gone outside of normal ranges. Note that this is a non-critical warning and immediate service is not required. However if the Sensor OK LED turns off then the monitor must be immediately serviced or taken off line.

The first step in troubleshooting a Pneumatic Error is determining which parameter has caused the warning. At the monitor front panel, navigate to the VIEW menu (See Section

6.2.5.) Examine the Flow and Pressure values and compare them to the limits described in Table 9-1 and take appropriate action as described below.

### 9.2.4.1. Pressure Too High

The monitor inlet is being pressurized. The monitor inlet should be allowed to sample gas at ambient pressure. Disconnect all sample lines from the monitor and read the pressure again. If the value then drops to within the acceptable range, then the sample lines is at elevated pressure.

If the inlet is being pressurized, then the design of the sample system should be reviewed and corrected. Contact Teledyne API Technical Support for assistance.

### 9.2.4.2. Pressure Too Low

Something may be restricting the flow through the monitor, causing the sample pump to pull a vacuum on the sensor module. First, unplug the sample pump power plug on the Mainboard PCA and observe the pressure reading. If the pressure reading is still too low, then likely there is a problem with the pressure sensor on the Sensor Module and the Sensor Module should be replaced. Next reconnect the pump and disconnect all sample lines from the monitor and see if the pressure increases to normal levels. If it does, then the problem is somewhere in the sampling system external to the monitor. If the pressure is still below the limit with the sample lines removed, then there is a restriction in the pneumatics of the monitor upstream of the sensor assembly. The most likely cause is a plugged particulate filter. Disconnect the outlet fitting on the sample filter and observe the pressure. If it returns to normal levels then the restriction is in the particulate filter. Replace particulate filter per Section 8.3.

## 9.3. Technical Support

Contact information for the TAPI Technical Support Department is as follows:

**Toll-free Phone:** 800-324-5190

**Phone:** +1 858-657-9800

**Fax:** +1 858-657-9816

**Email:** [api-techsupport@teledyne.com](mailto:api-techsupport@teledyne.com)

This page intentionally left blank.

# 10. CALIBRATION

---

## 10.1. Factory Calibration

The Model 465L+O<sub>2</sub> ozone portion is calibrated to NIST traceable standards on the 0-1 ppm range prior to shipment. The oxygen portion is also calibrated to NIST traceable standards. A calibration certificate for your instrument can be purchased from Teledyne API if required. Teledyne API also recommends that the Model 465L+O<sub>2</sub> be re-calibrated once a year. Teledyne API can provide NIST traceable calibration services at our factory or on-site. Please contact our Customer Service department for details on these services.

## 10.2. Zero Calibration

A zero calibration can be easily performed in the field, and Teledyne API recommends that this be done at least annually. See Section 6.2.4.4 for details on performing a zero calibration.

This page intentionally left blank.

# 11. SPARE PARTS

---

This section provides the names and part numbers of the spare parts for the M465L + O<sub>2</sub>. (Reference Spare Parts List PN 059100100).

## 11.1. M465L + O<sub>2</sub> Spare Parts List

PART NUMBER	DESCRIPTION
025710100	PCA, UV DETECTOR PREAMP
036280000	ASSY, WATER DROP OUT FILTER, PFA
036750000	AKIT, ELEMENTS, (FL26) 47MM, 30 MICRON
040031200	PCA, FLOW SENSOR,
046170000	ABSORPTION TUBE
046740000	ASSY, PUMP, 12VDC (OP63)
048490100	PCA, O3 BENCH
048990300	ASSY, HI-CON O3 SCRUBBER, CH71
049680000	ASSY, SENSOR, HI-CONC
049680100	ASSY, SENSOR, LO-CONC
050300000	ASSY, REF SCRUBBER, HI-CONC
050720300	PCA, MAINBOARD, CE
052640000	PCA, RELAY/VALVE EXPANSION
053010000	AKIT, EXP KIT, CARULITE 200
053130300	PCA, FRONT, MULTI CHL, CE
053130400	PCA, FRONT PANEL, SNGL CHL, CE
053200000	PCA, FRONT PANEL DAUGHTER BD, M465XXX
055090000	MANUAL, OPERATORS, M465L
058400001	ASSY, REF SCRUBBER, LO-CONC,*(OBS)
061760100	ASSY, FLOWMETER
062310000	AKIT, PRE-FILTERS, 1 STREAM
062680000	ASSY, ZERO SCRUBBER, OZONE
065660000	ASSY UV LAMP UVP OP39 GEN III
CN0000350	CONNECTOR, 16 PIN, W/SCREW FLANGE
DR0000006	DRYER, 24", 1/4" SS FITTINGS
FL0000033	DFU, KYNAR, 1/4" TUBE
HW0000120	SHOCKMOUNT, GROMMET ISOLATOR

<b>PART NUMBER</b>	<b>DESCRIPTION</b>
KIT000267	AKIT, M46XL PRE-FILTERS (FL37-25 pcs)
OP0000031	WINDOW, QUARTZ, 1/2"DIA, .063" THICK (KB
OR0000039	ORING, 2-012V
OR0000050	ORING, 2-014V
OR0000098	ORING, 2-108S
OR0000099	ORING, 2-129, CV-75 COMPOUND
OR0000104	ORING, 5-125V
PS0000042	PS, 60W SWITCHING, 2X4, 15V
VA0000054	MANIFOLD, 3-WAY VALVE, PEEK/VITON
076170000	FIRMWARE, M465 WITH OXYGEN SENSOR
076140200	MASK, OZONE / OXYGEN MONITOR - M465L+O2 / NEMA
076050100	PCA, O2 DAUGHTERBOARD, 465
076210000	MANIFOLD, O2 SENSOR, 465L
076830000	CBL, O2 SENSOR, TAI
CN0000646	SOCKET,DUAL ROW,16POS,STACKING,.394" LD
FT0000012	CONNECTOR-M, SS, 1/4" (KB)
HW0000076	STANDOFF, M/F, #6-32 X 1", SS
HW0000339	WASHER, NYLON, #6, .250 OD, .140 ID,
C43690-R17A	SENSOR, O2, R17A
SN0000005	SCW, PH, P, SS, #6-32x3/8, SEMS
SN0000056	SCW, PH, P, SS, #8-32x5/8



# INDEX

- Accuracy
  - sample filtration, 24
  - sampling lines, 24
  - Specifications, 13
- Analog Output
  - Specifications, 14
- Cleanliness in pneumatic system
  - importance of, 24
- Connection
  - Ethernet, 30
  - RS232, 30
  - RS485, 30
- Diagnostic LEDs, 28
- Dimensions
  - Specifications, 13
- Environmental Conditions
  - Specifications, 14
- Humid Environments, 24
- Humidity Range
  - Specifications, 13
- Isolated Analog Output
  - Specifications, 14
- Lower Detectable Limit
  - Specifications, 13
- Measurement Units
  - Specifications, 13
- Noise
  - Specifications, 13
- Option
  - Flowmeter, 31
  - Permeation Gas Dryer, 26, 31
  - Sample Conditioner, 26, 31
- Permeation Gas Dryer, 26**
  - Power
    - Specifications, 13
  - Ranges
    - Specifications, 13
  - Response Time
    - Specifications, 13
  - rument Status Outputs
    - Specifications, 14
  - Safety Messages
    - General, iii, 57, 59, 60
- Sample Conditioner, 26**
  - Sample Filtration Accuracy, 24
  - Sample Flow Rate
    - Specifications, 13
  - Sample gas connection, 23
- Spare Parts
  - for NEMA units, 77
- Startup
  - initial behavior, 22
- Status Relay
  - Specifications, 14
- Teledyne Contact Information**
  - Email Address, 14, 73**
  - Fax, 14, 73**
  - Phone, 14, 73**
  - Temperature Range
    - Specifications, 13
  - UV Lamp, 57, 59, 60
  - uv Light, 57, 59, 60
  - UV light absorption, 15
  - Weight
    - Specifications, 13